

CD Stereo System

SC-AK95

SC-AK75

Operating Instructions

Panasonic®

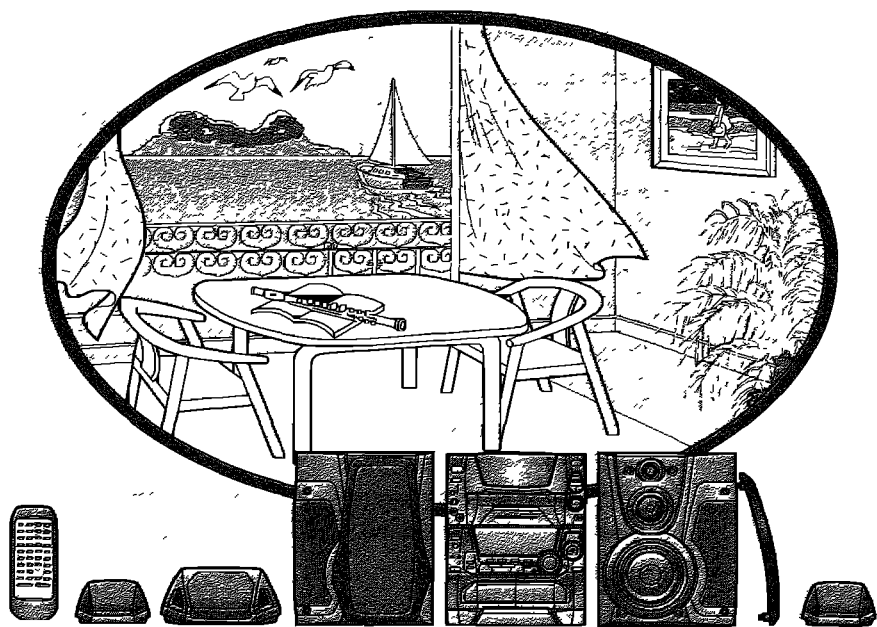

The illustrations show SC-AK95

COMPACT
disc
DIGITAL AUDIO
TEXT

P PC

Before connecting, operating or adjusting this product, please read these instructions completely. Please save this manual.

RQT4220-1P

Dear customer

Thank you for purchasing this product.
For optimum performance and safety, please read these instructions carefully.

These operating instructions are applicable to the following systems.
These operating instructions, however, fundamentally explain the operation of system SC-AK95.

System		SC-AK95	SC-AK75
Main unit		SA-AK95	SA-AK75
Speakers	Front	SB-AK95	SB-AK75
	Center	SB-PC55	—
	Surround	SB-PS55	SB-PS55A

The model number and serial number of this product can be found on either the back or the bottom of the unit.
Please note them in the space provided below and keep for future reference.

	MODEL NUMBER	SERIAL NUMBER
Main unit	_____	_____
Speakers	_____	_____

User memo:

DATE OF PURCHASE _____
DEALER NAME _____
DEALER ADDRESS _____
TELEPHONE NUMBER _____

CAUTION!

THIS PRODUCT UTILIZES A LASER.
USE OF CONTROLS OR ADJUSTMENTS OR PERFORMANCE OF PROCEDURES OTHER THAN THOSE SPECIFIED HEREIN MAY RESULT IN HAZARDOUS RADIATION EXPOSURE.

DO NOT OPEN COVERS AND DO NOT REPAIR YOURSELF. REFER SERVICING TO QUALIFIED PERSONNEL.

CAUTION:

TO PREVENT ELECTRIC SHOCK MATCH WIDE BLADE OF PLUG TO WIDE SLOT, FULLY INSERT.

Table of Contents

Before use

Supplied accessories	2
Precautions	4
Concerning the remote control	5
Placement of speakers	6
Connections	7
Basic connections (for supplied accessories)	7
Optional antenna connections	8
External unit connection	8
Front panel controls	9

Preparations

Demo function	11
Setting the time	11
Presetting radio broadcasts	12

Radio operations

Listening to radio broadcasts	13
-------------------------------------	----

CD operations

Listening to CDs	14
Setting/Removing CDs	14
Sequential play	15
Direct access play	16
Single CD play	17
Repeat play	17
Random play	17
Program play	18
To listen to special CDs and tracks (CD MANAGER function)	20
CD-TEXT function	21

Tape deck operation

Listening to tapes	25
--------------------------	----

Supplied accessories

 Please check and identify the supplied accessories.
Use numbers indicated in parentheses when asking for replacement parts.
(Only for U.S.A.)
To order accessories contact 1-800-211-7262 or web site (<http://www.panasonic.com>).

AC power supply cord
 1 pc. (SJA172) |

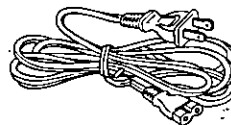

FM indoor antenna (RSA0006-J)
 1 pc. |



AM loop antenna set (RSA0022)
 1 pc. |

- AM loop antenna
- AM antenna holder



Dear customer

Thank you for purchasing this product
For optimum performance and safety, please read these instructions carefully

These operating instructions are applicable to the following systems

These operating instructions, however, fundamentally explain the operation of system SC-AK95

System		SC-AK95	SC-AK75
Main unit		SA-AK95	SA-AK75
Speakers	Front	SB-AK95	SB-AK75
	Center	SB-PC55	—
	Surround	SB-PS55	SB-PS55A

The model number and serial number of this product can be found on either the back or the bottom of the unit
Please note them in the space provided below and keep for future reference

	MODEL NUMBER	SERIAL NUMBER
Main unit	_____	_____
Speakers	_____	_____

User memo:

DATE OF PURCHASE _____
DEALER NAME _____
DEALER ADDRESS _____
TELEPHONE NUMBER _____

CAUTION!

**THIS PRODUCT UTILIZES A LASER.
USE OF CONTROLS OR ADJUSTMENTS OR PERFORMANCE OF PROCEDURES OTHER THAN THOSE SPECIFIED HEREIN MAY RESULT IN HAZARDOUS RADIATION EXPOSURE.
DO NOT OPEN COVERS AND DO NOT REPAIR YOURSELF. REFER SERVICING TO QUALIFIED PERSONNEL.**

CAUTION:

TO PREVENT ELECTRIC SHOCK MATCH WIDE BLADE OF PLUG TO WIDE SLOT, FULLY INSERT.

Table of Contents

Before use

Supplied accessories	2
Precautions	4
Concerning the remote control	5
Placement of speakers	6
Connections	7
Basic connections (for supplied accessories)	7
Optional antenna connections	8
External unit connection	8
Front panel controls	9

Preparations

Demo function	11
Setting the time	11
Presetting radio broadcasts	12

Radio operations

Listening to radio broadcasts	13
-------------------------------	----

CD operations

Listening to CDs	14
Setting/Removing CDs	14
Sequential play	15
Direct access play	16
Single CD play	17
Repeat play	17
Random play	17
Program play	18
To listen to special CDs and tracks (CD MANAGER function)	20
CD-TEXT function	21

Tape deck operation

Listening to tapes	25
--------------------	----

Supplied accessories

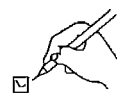

Please check and identify the supplied accessories

Use numbers indicated in parentheses when asking for replacement parts

(Only for U.S.A.)

To order accessories contact 1-800-211-7262 or web site (<http://www.panasonic.com>)

- AC power supply cord (SJA172) 1 pc

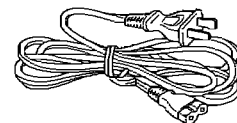

- FM indoor antenna (RSA0006-J) 1 pc



- AM loop antenna set (RSA0022) 1 pc
 • AM loop antenna 1 pc
 • AM antenna holder 1 pc



Sound quality/sound field operation

Using the built-in sound quality/sound field settings	27
Boosting the super woofer	27
Varying the sound quality with the acoustic image (AI) equalizer	28
Varying the sound quality with the manual equalizer	29
Enjoying sound with DOLBY PRO LOGIC	30

Recording operations

Before recording	32
Recording from radio broadcasts	33
Recording from CDs	34
Tape-to-tape recording	36

Convenient functions

Convenient functions	37
----------------------	----

KARAOKE operations

Singing along with KARAOKE	38
----------------------------	----

Timer

Using the timer	40
-----------------	----

Reference

Using an external unit	43
Concerning CDs	44
Concerning cassette tapes	44
Technical specifications	45
Troubleshooting guide	46
Maintenance	47
Before moving or shipping this system	Back cover
Product service	Back cover

- Remote control transmitter 1 pc.
SC-AK95
 (RAK-CH938WK)
- Batteries 2 pcs.
 (R6/LR6, AA size, UM-3)

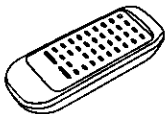

SC-AK75
 (RAK-CH939WK)

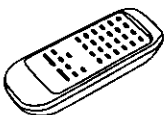

THE FOLLOWING APPLIES ONLY IN THE U.S.A.:

CAUTION:

This equipment has been tested and found to comply with the limits for a Class B digital device, pursuant to Part 15 of the FCC Rules.

These limits are designed to provide reasonable protection against harmful interference in a residential installation. This equipment generates, uses and can radiate radio frequency energy and, if not installed and used in accordance with the instructions, may cause harmful interference to radio communications. However, there is no guarantee that interference will not occur in a particular installation. If this equipment does cause harmful interference to radio or television reception, which can be determined by turning the equipment off and on, the user is encouraged to try to correct the interference by one of the following measures:

- Reorient or relocate the receiving antenna.
- Increase the separation between the equipment and receiver.
- Connect the equipment into an outlet on a circuit different from that to which the receiver is connected.
- Consult the dealer or an experienced radio/TV technician for help.

FCC Notice: This system complies with new Part 15, except for the radio receiver, which complies with old Part 15, Subpart C of the FCC Rules. Operation is subject to the following two conditions: (1) This device may not cause harmful interference, and (2) this device must accept any interference received, including interference that may cause undesirable operation. The radio receiver is not subject to above item (2).

Any unauthorized changes or modifications to this equipment would void the user's authority to operate this device.

WARNING:

TO REDUCE THE RISK OF FIRE, ELECTRIC SHOCK OR PRODUCT DAMAGE, DO NOT EXPOSE THIS APPLIANCE TO RAIN, SPLASHING, DRIPPING OR MOISTURE.



CAUTION

**RISK OF ELECTRIC SHOCK
DO NOT OPEN**



CAUTION: TO REDUCE THE RISK OF ELECTRIC SHOCK, DO NOT REMOVE SCREWS. NO USER-SERVICEABLE PARTS INSIDE. REFER SERVICING TO QUALIFIED SERVICE PERSONNEL.



The lightning flash with arrowhead symbol, within an equilateral triangle, is intended to alert the user to the presence of uninsulated "dangerous voltage" within the product's enclosure that may be of sufficient magnitude to constitute a risk of electric shock to persons.



The exclamation point within an equilateral triangle is intended to alert the user to the presence of important operating and maintenance (servicing) instructions in the literature accompanying the appliance.

Precautions

Before using this unit please read these operating instructions carefully. Take special care to follow the warnings indicated on the unit itself as well as the safety suggestions listed below. Afterwards keep them handy for future reference.

Safety

1. **Power Source**—The unit should be connected to power supply only of the type described in the operating instructions or as marked on the unit.
2. **Polarization**—If the unit is equipped with a polarized AC power plug (a plug having one blade wider than the other), that plug will fit into the AC outlet only one way. This is a safety feature. If you are unable to insert the plug fully into the outlet, try reversing the plug. If the plug should still fail to fit, contact your electrician to replace your obsolete outlet. Do not defeat the safety purpose of the polarized plug.
3. **Power Cord Protection**—AC power supply cords should be routed so that they are not likely to be walked on or pinched by items placed upon or against them. Never take hold of the plug or cord if your hand is wet, and always grasp the plug body when connecting or disconnecting it.
4. **Nonuse Periods**—When the unit is not used, turn the power off. When left unused for a long period of time, the unit should be unplugged from the household AC outlet.

Installation

Environment

1. **Outdoor Antenna Grounding**—If an outside antenna is connected to the receiver, be sure the antenna system is grounded so as to provide some protection against voltage surges and built-up static charges. Section 810 of the National Electrical Code, ANSI/NFPA No. 70-1990, provides information with respect to proper grounding of the mast and supporting structure, grounding of the lead-in wire to an antenna discharge unit, size of grounding conductors, location of antenna-discharge unit, connection to grounding electrodes, and requirements for the grounding electrode. See figure below.

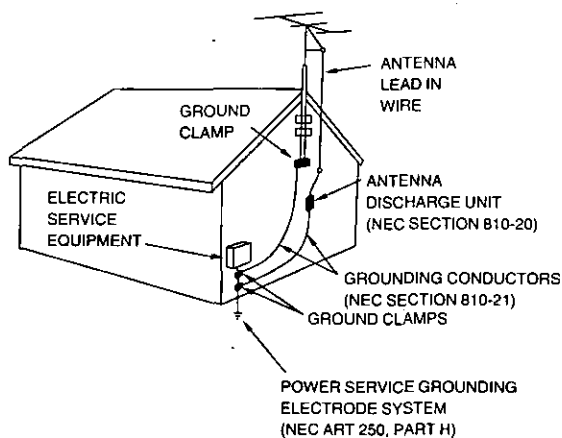

NEC—NATIONAL ELECTRICAL CODE

2. **Water and Moisture**—Do not use this unit near water—for example, near a bathtub, washbowl, swimming pool, or the like. Damp basements should also be avoided.

3. **Heat**—The unit should be situated away from heat sources such as radiators and the like. It also should not be placed in temperatures less than 5°C (41°F) or greater than 35°C (95°F).
4. **Condensation**—Moisture may form on the lens in the following conditions...
 - immediately after a heater has been turned on.
 - in a steamy or very humid room.
 - when the unit is suddenly moved from a cold environment to a warm one.If moisture forms inside this unit, it may not operate properly. To correct this problem, turn on the power and wait about one hour for the moisture to evaporate.

Placement

1. **Ventilation**—The unit should be situated so that its location or position does not interfere with its proper ventilation. Allow 10 cm (4") clearance from the rear of the unit.
2. **Foreign Material**—Care should be taken so that objects do not fall into and liquids are not spilled into the unit. Do not subject this unit to excessive smoke, dust, mechanical vibration, or shock.
3. **Magnetism**—The unit should be situated away from equipment or devices that generate strong magnetic fields.
4. **Stacking**—Do not place heavy objects, other than system components, on top of the unit.
5. **Surface**—Place the unit on a flat, level surface.
6. **Carts and Stands**—The unit should be used only with a cart or stand that is recommended by the manufacturer. The unit and cart combination should be moved with care. Quick stops, excessive force, and uneven surfaces may cause the unit and cart combination to overturn.
7. **Wall or Ceiling Mounting**—The unit should not be mounted to a wall or ceiling, unless specified in this operating instructions.



Maintenance

(→ page 47 for details.)

Clean the cabinet, panel and controls with a soft cloth lightly moistened with mild detergent solution. Do not use any type of abrasive pad, scouring powder or solvent such as alcohol or benzine.

Service

1. **Damage Requiring Service**—The unit should be serviced by qualified service personnel when:
 - (a) The AC power supply cord or the plug has been damaged; or
 - (b) Objects have fallen or liquid has been spilled into the unit; or
 - (c) The unit has been exposed to rain; or
 - (d) The unit does not appear to operate normally or exhibits a marked change in performance; or
 - (e) The unit has been dropped, or the enclosure damaged.
2. **Servicing**—The user should not attempt to service the unit beyond that described in the operating instructions. All other servicing should be referred to an authorized service personnel. For the address of an authorized servicenter:
In the U.S.A. 1-800-211-7262 or web site (<http://www.panasonic.com>)
In Canada 905-624-5505 or web site (www.panasonic.ca/fdbckca.htm)

Listening caution



Selecting fine audio equipment such as the unit you've just purchased is only the start of your musical enjoyment. Now it's time to consider how you can maximize the fun and excitement your equipment offers. This manufacturer and the Electronic Industries Association's Consumer Electronics Group want you to get the most out of your equipment by playing it at a safe level. One that lets the sound come through loud and clear without annoying blaring or distortion—and, most importantly, without affecting your sensitive hearing.

We recommend you to avoid prolonged exposure to excessive noise.

Sound can be deceiving. Over time your hearing "comfort level" adapts to higher volumes of sound. So what sounds "normal" can actually be loud and harmful to your hearing.

Guard against this by setting your equipment at a safe level BEFORE your hearing adapts.

To establish a safe level:

- Start your volume control at a low setting.
- Slowly increase the sound until you can hear it comfortably and clearly, and without distortion.

Once you have established a comfortable sound level:

- Set the dial and leave it there.

Taking a minute to do this now will help to prevent hearing damage or loss in the future. After all, we want you listening for a lifetime.

Concerning the remote control

Battery installation

(R6/LR6
AA size, UM-3)

Insert the batteries in the correct polarities (⊕, ⊖).

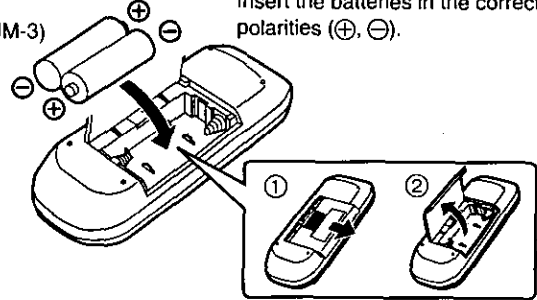

Use of batteries

- Do not mix old and new batteries, or batteries of different types (manganese and alkaline, etc.).
- Never subject batteries to excessive heat or flame; do not attempt to disassemble them; and be sure they are not short-circuited.
- If the remote control is not to be used for a long period of time, remove the batteries and store them in a cool, dark place.
- Do not attempt to recharge alkaline or manganese batteries.
- Do not use rechargeable type batteries.

Battery life

The battery life is about one year.

The batteries should be replaced if commands from the remote control transmitter do not operate the unit even when the transmitter is held close to the front panel.

Correct method of use

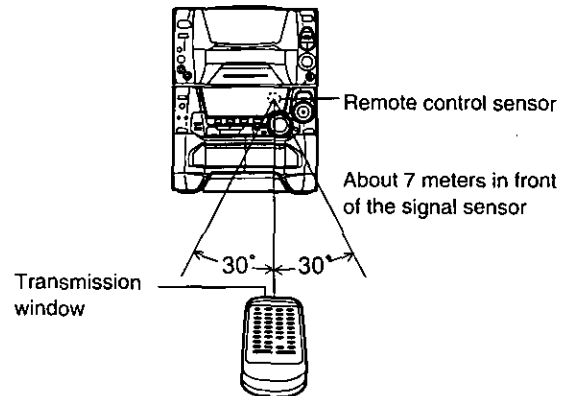

Operation notes

- Do not place obstacles between the remote control signal sensor and remote control unit.
- Do not expose the remote control signal sensor to direct sunlight or to the bright light of an inverter fluorescent light.
- Take care to keep the remote control signal sensor and end of the remote control unit free from dust.
- If this system is installed in a rack with glass doors, the glass doors' thickness or color might make it necessary to use the remote control a shorter distance from the system.

To prevent damage

- Never place heavy items on top of the unit.
- Do not disassemble or reconstruct the unit.
- Do not spill water or other liquids into the unit.

A

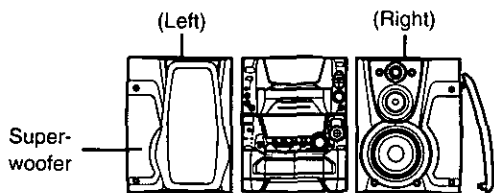

B

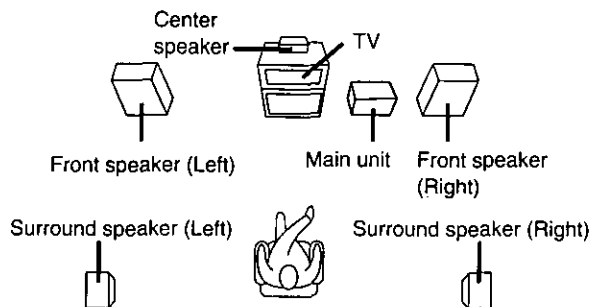

C

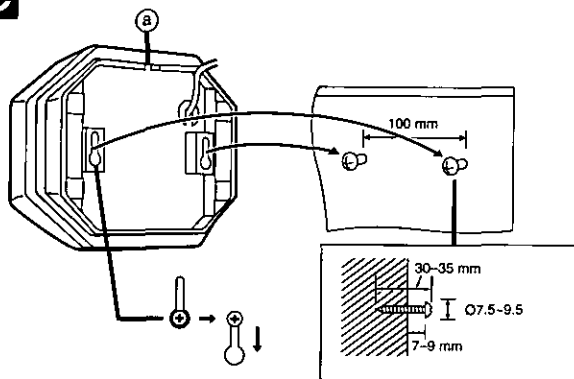

Placement of speakers

Placement of front speakers

For your listening pleasure, keep your speakers from touching the system.

Place the speakers so that the superwoofer is on the outside. **A**

Placement of center/surround speakers **B**

Center speaker

SC-AK95 only

Place the center speaker above or below the television, as close to the television as possible.

Surround speakers

As well as enjoying normal stereo reproduction with the left and right front speakers, surround speakers can also be connected to the system in order to enjoy a feeling of depth and movement of sound.

Check the L (Left) or R (Right) channels indication on the underside of the speakers for correct placement. Place the speakers with the Panasonic logo facing toward the listening position.

We recommend that surround speakers be placed on the side of or slightly behind the listener at ear level.

However the position should be adjusted to your personal preference, because the effect varies to some degree depending upon the type of music and the music source.

Attaching to a wall **C**

Set speaker onto screws and slide through bracket to lock into position.

Note

The wall or pillar on which the speaker systems are to be attached should be capable of supporting a weight of 5 kilograms.

For your reference

To fix the wire feed it through slit **a** in the speaker.



Caution

Use the speakers only with the recommended system. Failure to do so may lead to damage to the amplifier and/or the speakers, and may result in the risk of fire. Consult a qualified service person if damage has occurred or if you experience a sudden change in performance.

Note

The front speakers (and center speaker) are made so they can be used in close proximity of a TV, but irregular coloring may result due to how the system is placed. If such distortion occurs, turn off the TV for between 15 and 30 minutes. The demagnetizing function of the TV will eliminate the distortion. If the irregular coloring is still visible when the TV is turned on again, move the speakers further away from the TV.

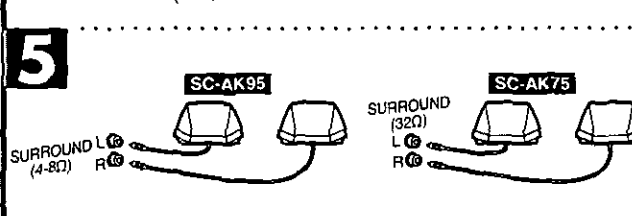
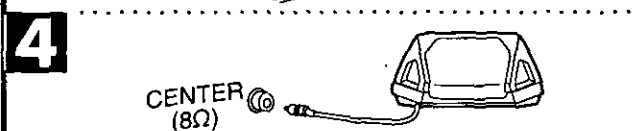
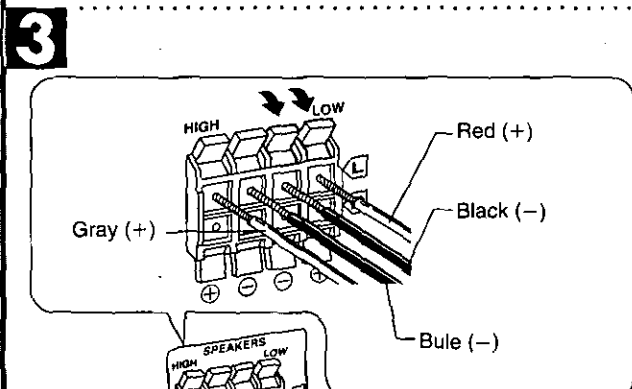
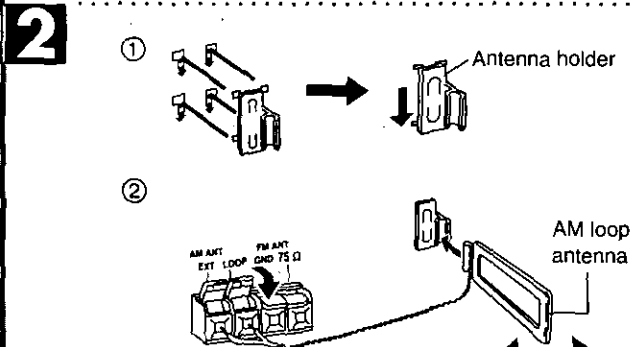
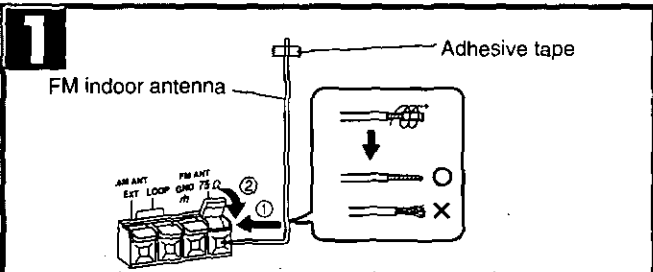
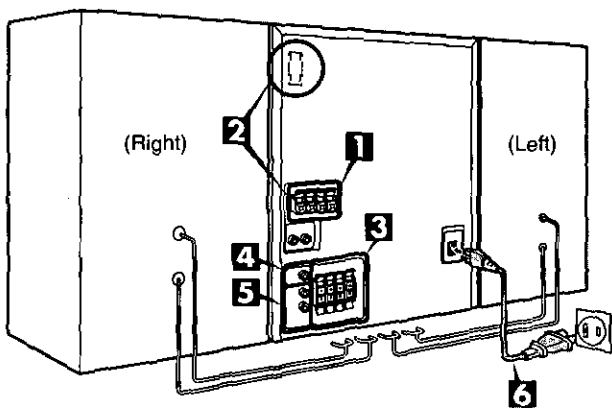

Connections

Basic connections (for supplied accessories)

- Plug the AC power cord into a household AC outlet only after all other connections have been made.
- To prepare the FM indoor antenna, the AM loop antenna wire and speaker cords, twist the vinyl cover tip and pull off.

1 Connect the FM indoor antenna.

Tape the antenna to a wall or column, in a position where radio signals are received with the least amount of interference.

Note

For best reception sound quality:

An FM outdoor antenna is recommended (⇒ page 8).

2 Connect the AM loop antenna.

After attaching the antenna, turn on the system and tune in a broadcast station. Then, turn the antenna to the angle of best reception and least interference.

3 Connect the front speakers.

Connect each end of the speaker cables to the terminal lever of the same color.

When speakers are connected to the low and high terminals on the back of the main unit

They are designed to have a combined impedance of 6Ω.

Be sure to use only the speakers supplied.

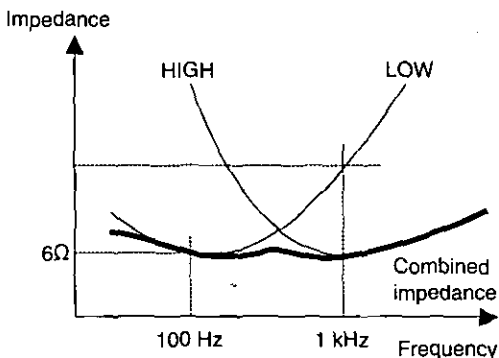

Caution

• Never use speakers other than those supplied. For instance, if you connect speakers with an impedance of 6Ω each and plug them into the low and high terminals, you will only have a combined impedance of 3Ω.

• To prevent damage to circuitry, never short-circuit positive (+) and negative (-) speaker wires.

4 SC-AK95 only

Connect the center speaker.

5 Connect the surround speakers.

Note

If only one of the surround speakers is connected, no sound will come out. Be sure to connect both speakers.

6 Connect the AC power cord.

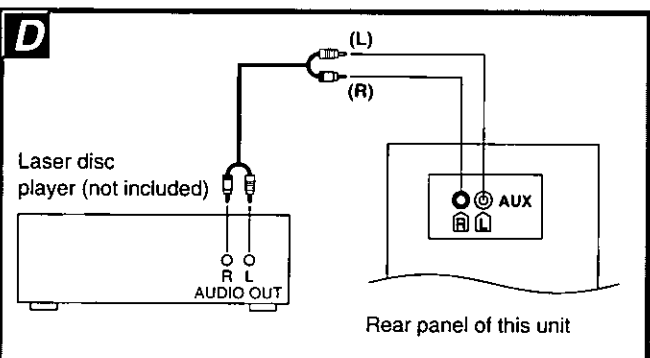
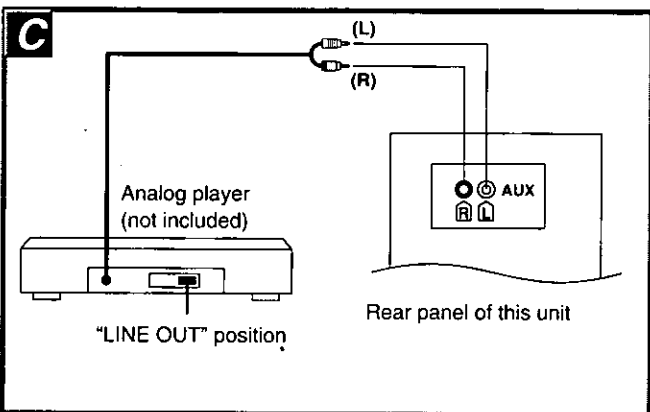
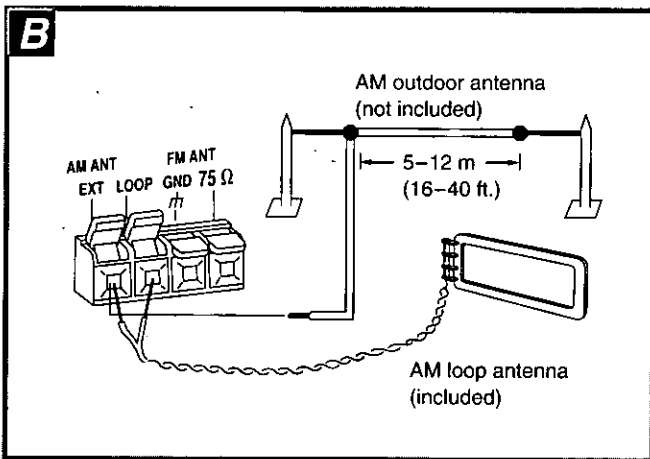
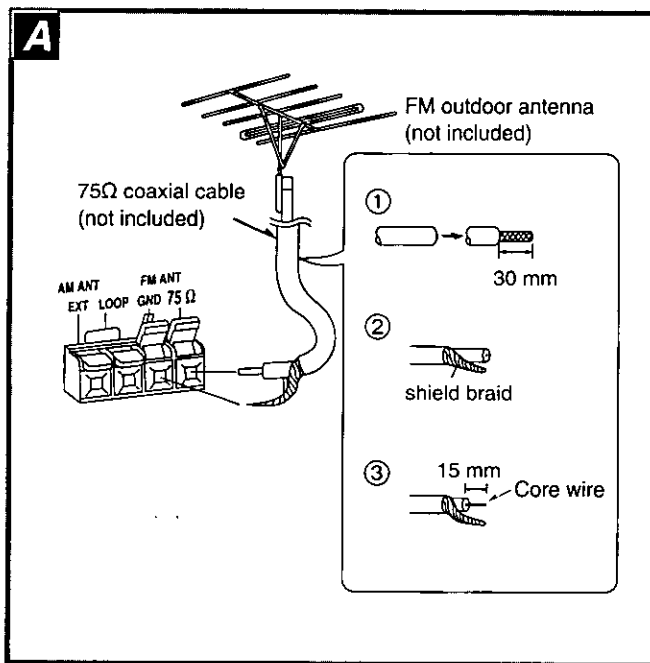

Connections

Optional antenna connections

You may need an outdoor antenna if you use this system in a mountainous region or inside a reinforced-concrete building, etc.

FM outdoor antenna **A**

Disconnect the FM indoor antenna if an FM outdoor antenna is installed.

- ① Remove a piece of the outer vinyl insulator.
- ② Twist the shield braid.
- ③ Expose the core wire.

Note

An outdoor antenna should be installed by a qualified technician only.

AM outdoor antenna **B**

Connect the outdoor antenna without removing the AM loop antenna. Run 5 to 12 m of vinyl-covered wire horizontally along a window or other convenient location.

Note

When the unit is not in use, disconnect the outdoor antenna to prevent possible damage that may be caused by lightning. Never use an outdoor antenna during an electrical storm.

External unit connection

- For details, refer to the instruction manuals of the units which are to be connected.
- When units other than these are to be connected, please consult with your audio dealer.

This example shows how to connect an analog player with a PHONO OUT/LINE OUT switch. **C**

Note

- Only analog players with built-in phono equalizers can be connected.
- Set the switch on the back of the analog player to "LINE OUT".

SC-AK95 only **D**

This unit has Dolby Pro Logic circuitry. If the audio output of video equipment is connected to the AUX terminal of this unit, the sound will be reproduced with the same powerful stereophonic effects found in movie theaters (→ page 30).

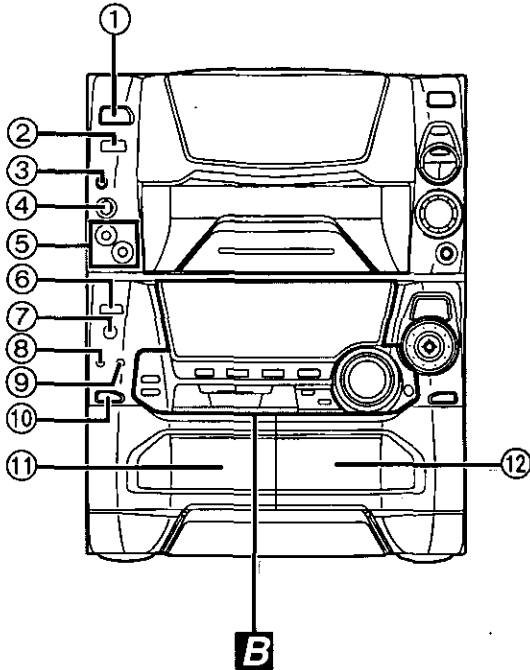
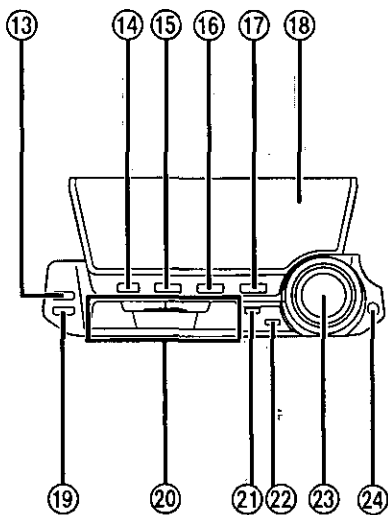
A**B**

Front panel controls

Main unit **A**

No.	Name	Ref. page
①	Power "STANDBY ⏻/ON" switch (POWER, STANDBY ⏻/ON) 11 Press to switch the unit from on to standby mode or vice versa. In standby mode, the unit is still consuming a small amount of power.	11
②	Single play button (SINGLE \blacktriangleright) 17	17
③	SC-AK95 only Karaoke button (KARAOKE) 38	38
④	SC-AK95 only Microphone volume control (MIC VOL) 38	38
⑤	SC-AK95 only Microphone jacks (MIC1, MIC2) 38	38
⑥	SC-AK95 only DOLBY PRO LOGIC on/off button (DOLBY PRO LOGIC) 30	30
⑦	SC-AK95 only Center mode select button (CENTER MODE) 30	30
⑧	Play timer/record timer button (⌚ PLAY/⌚ REC) 40, 41	40, 41
⑨	Clock/timer button (CLOCK/TIMER) 11, 40, 41	11, 40, 41
⑩	Deck 1 open button (DECK 1, \blacktriangle OPEN) 25	25
⑪	Deck 1 cassette holder 25	25
⑫	Deck 2 cassette holder 25	25

Center console **B**

⑬	Display select/demonstration button (-DISPLAY/-DEMO) 11, 37	11, 37
⑭	AUX button (AUX) 43	43
⑮	Tape/deck select button (TAPE, DECK 1/2) 25	25
⑯	CD button (CD) 15	15
⑰	Tuner/band select button (TUNER, BAND) 12	12
⑱	Display panel	
⑲	Reverse mode select button (REV MODE) 25	25
⑳	Basic operating buttons Functions change according to the source.	
㉑	Recording start/stop button (\bullet REC/STOP) 33	33
㉒	Tape edit button (TAPE EDIT) 36	36
㉓	Volume control (VOLUME) 13	13
㉔	Super woofer on/off button (SUPER WOOFER) 27	27

A

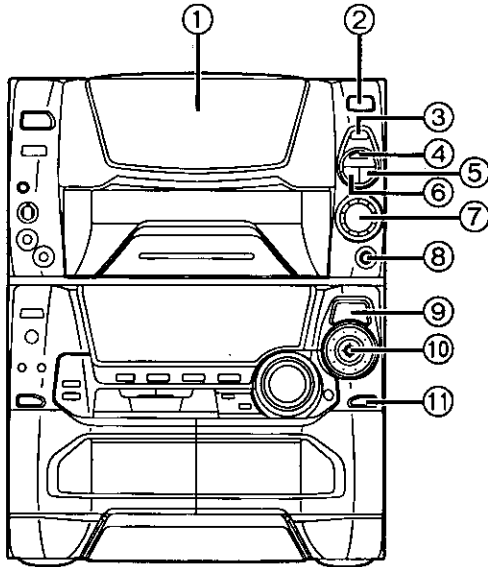

Front panel controls

Main unit (continued)

No.	Name	Ref. page
①	CD rack panel	14
②	CD rack panel open button (OPEN)	14
③	CD MANAGER button (CD MANAGER)	20, 35
④	Disc/track select button/indicator (DISC/TRACK)	15
⑤	Text edit button (TEXT EDIT)	23
⑥	Text mode select button (TEXT MODE)	21
⑦	Jog dial (JOG)	15
⑧	Headphone jack (PHONES)	43
⑨	Acoustic image equalizer display (AI EQ)	28
⑩	Sound equalizer control/indicator (SOUND EQ)	27
⑪	Deck 2 open button (DECK 2 OPEN)	25

Remote control

Buttons such as ⑫ function in exactly the same way as the buttons on the main unit.

⑫	Power button (POWER)	11
⑬	Numeric buttons	16
⑭	Program button (PROGRAM)	18
⑮	Cancel button (CANCEL)	19
⑯	Input selection buttons (AUX, TAPE, CD, TUNER)	12, 15, 25, 43
⑰	SC-AK95 only Channel select button (CH SELECT)	31
⑱	SC-AK95 only DOLBY PRO LOGIC on/off button (DOLBY PRO LOGIC)	30
⑲	Muting button (MUTING)	37
⑳	◀/√ button (◀/√)	13, 25
㉑	Sleep button (SLEEP)	43
㉒	Equalizer button (EQ)	27
㉓	Super woofer on/off button (S. WOOFER)	27
㉔	Disc button (DISC)	18
㉕	Random button (RANDOM)	17
㉖	Repeat button (REPEAT)	17
㉗	SC-AK95 only Channel level select buttons (- CH LEVEL +)	31
㉘	SC-AK95 only Test button (TEST)	31
㉙	⏮/⏪ ⏩/⏭ buttons (⏮/⏪ ⏩/⏭)	15, 26
㉚	▶/⏸/⏹ button (▶/⏸/⏹)	13, 15, 25
㉛	Stop button (■)	15, 25
㉜	Volume buttons (- VOLUME +)	13

B

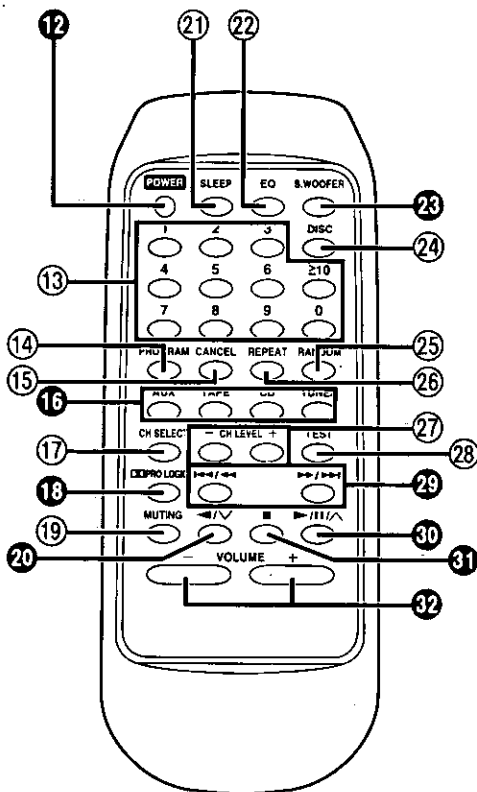

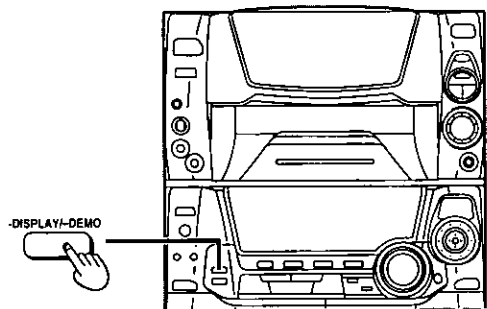
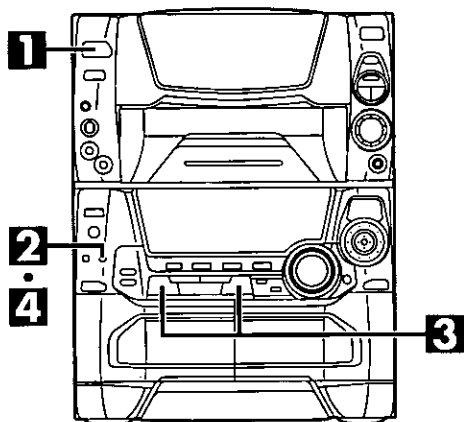
A**B**

1

2

↓

3

↓

4

↓

Demo function

When the demo function is activated, a demonstration of the spectrum analyzer using space travel images is shown on the display panel.

Turning the demo function ON/OFF

Press POWER and hold down DISPLAY/DEMO. Every time you hold down the button;

DEMO (ON) ← → NO DEMO (OFF)

When the demo function is ON, the demo is played automatically in the following cases.

- **When the system is ON**
If the input source is set to CD or tape, and the system is stopped for more than 2 minutes
- **When the system is OFF**
If the clock has not been set

Setting the time

This is a 12-hour display clock.

This example in the figure shows how to set the time for 4:25 p.m.

- 1** Switch on the power.
- 2** Press CLOCK/TIMER to select "CLOCK".
Every time you press the button;
CLOCK → PLAY → REC
↑ Previous display ←
- 3** (within 7 seconds or so)
Press ∇ or \blacktriangle to show the present time.
- 4** Press CLOCK/TIMER to finish setting the time.
The display will return to whatever was displayed before you set the time.

To display the time when power is ON

Press CLOCK/TIMER to select "CLOCK".

The time will be displayed for about 5 seconds and then the display will return to whatever was previously displayed.

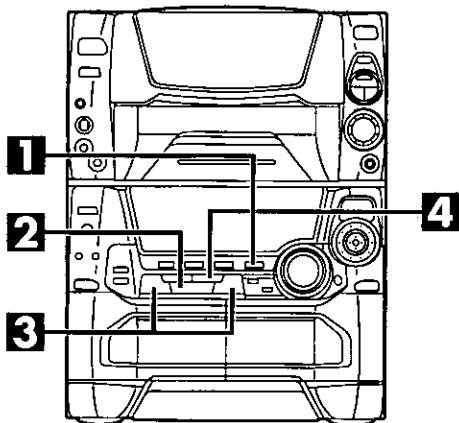

1

2

3

4

↓

Preset channel

Presetting radio broadcasts

- Up to 12 stations can be set in each band with the automatic or manual memory presetting.
- If broadcast frequencies are preset in the memory, you can easily tune in any of these frequencies from the system or remote control unit.
- You can preset just those stations you like. (See "Presetting only your favorite stations" below.)

1 Press TUNER BAND to select the band.

The power will come on automatically.
Every time you press the button; "FM" ↔ "AM".

2 Press TUNE MODE to select "MANUAL".

Every time you press the button; "MANUAL" ↔ "PRESET".

3 Press ∇ or \blacktriangle until the display shows the frequency from which you want to begin automatic memory presetting.

Tips on tuning in radio stations

- ① Hold down either arrow button until the frequency numbers start scrolling.
Continue to hold the button.
- ② When near to the frequency you are looking for, press the button repeatedly until the station is tuned in.

4 Press and hold MEMORY until the frequency begins to change.

This will start presetting automatically. When finished, the radio will tune in the last station memorized.

If auto presetting is not possible because radio signals are weak or for some other reason, do the following.

Presetting only your favorite stations

Preset the stations one at a time.

1. Perform step 1 above. Then, press MEMORY ("MEMO" flashes) and select a station with ∇ and \blacktriangle .
2. While "MEMO" is flashing press MEMORY again and select a preset channel with ∇ or \blacktriangle .
3. Press MEMORY to preset the station.

Memory retention

The memory can retain presetting for up to two weeks after being disconnected from the power source.

FM allocation settings:

The FM frequency step is set to 0.2 MHz at the time of shipment. By adjusting the allocation as shown below, you can enable the system to receive FM broadcasts allocated in 0.1 MHz steps.

1. Press and hold TUNER BAND for approximately 5 seconds.
The frequency display will be returned to the minimum frequency of the FM band and the display will begin to flash.
Keep holding for approximately 5 more seconds.
2. When the display stops flashing and indicates a different frequency number (the frequency step is changed to 0.1 MHz.), release TUNER BAND.

To return to the original frequency, repeat steps 1 to 2 above.

Note

After changing the "allocation" setting, the frequencies you previously preset in the memory will be cleared.

Listening to radio broadcasts

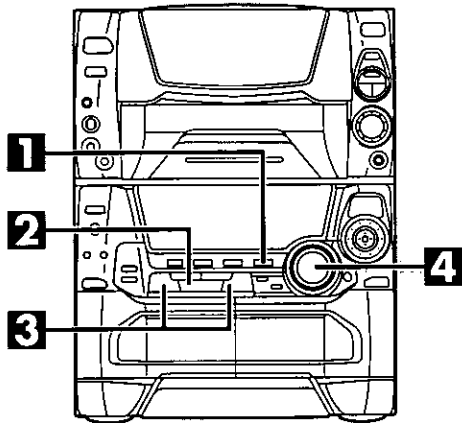

1 Press TUNER BAND to select band.

The power will come on automatically.

Every time you press the button; "FM" ↔ "AM".

2 Press TUNE MODE to select "PRESET" or "MANUAL".

Every time you press the button; "MANUAL" ↔ "PRESET".

PRESET: For preset stations

MANUAL: For non-preset stations

3 Press ∇ or \blacktriangle to select the desired broadcast.

"STEREO" lights when an FM stereo broadcast is being received. "TUNED" lights when you precisely tune in a station.

4 Adjust the volume level.

Auto tuning

Auto tuning is an easy way to tune in non-preset stations in the manual mode.

Hold down either ∇ or \blacktriangle , and release the button when the frequency starts scrolling.

The radio will stop automatically on the first station it picks up.

•When there is outside interference, the radio sometimes stops on a certain frequency where no station is broadcasting.

To stop auto tuning

Press either ∇ or \blacktriangle again.

If noise is excessive in the FM stereo mode \square

Press FM MODE/BP. ("MONO" will light up.)

Sound will be produced in monaural, but this also reduces noise.

Press the button again to cancel. "MONO" will go out.

Normally, you'll want to listen in stereo, so leave "MONO" off. This way, you can listen to stereo broadcasts in stereo, and monaural broadcasts in mono.

You can preset an FM station in monaural by following the steps under "Presetting only your favorite stations" (= page 12). After selecting the station in step 1, select "MONO" with FM MODE/BP, then continue with steps 2 and 3.

Note

•If you preset stations in memory, you can tune in a preset station by simply selecting the preset channel with the numeric buttons on the remote control.

1. Press TUNER on the remote control.

2. Press the numeric button(s) to select the desired preset channel.

To select a two-digit channel:

Press ≥ 10 and then the two numbers you want within 10 seconds or so.

•Sound is momentarily interrupted if you load/unload tapes while listening to an AM broadcast.

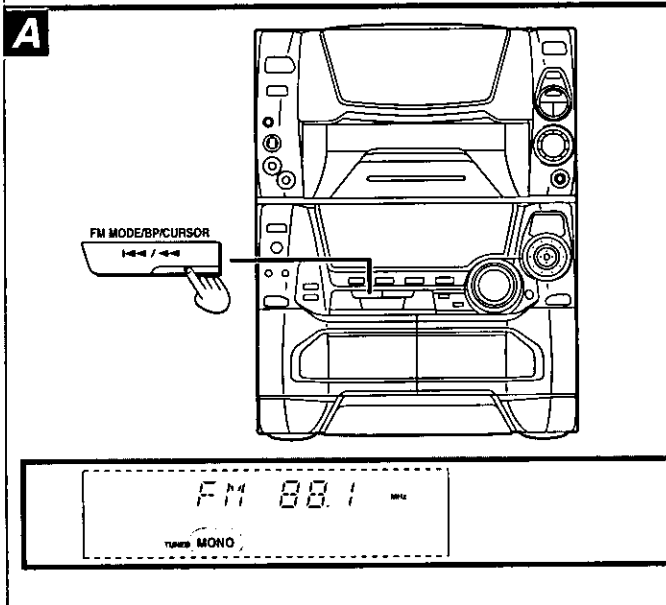
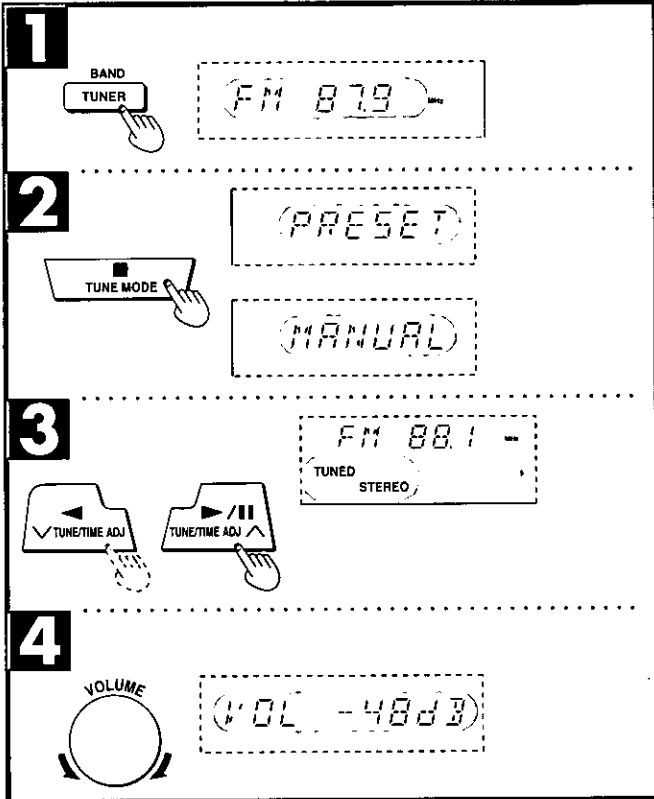

Setting/Removing CDs

You can set and remove CDs while a CD is playing.

How to set CDs

1. Open the rack panel.

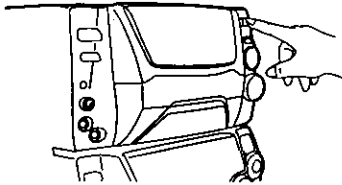

Note

Except when setting or removing CDs, keep hands out of the changer while open. You could injure yourself if somehow entangled in the internal mechanism.

2. Slide the loader carriage to the slot you want.

Note

The loader carriage has a LOCK position (when the lever is down) and a RELEASE position (when the lever is up). When you slide the loader carriage to select the slot you want, make sure it is in the RELEASE position.

You can read the numbers between the prongs as shown below.

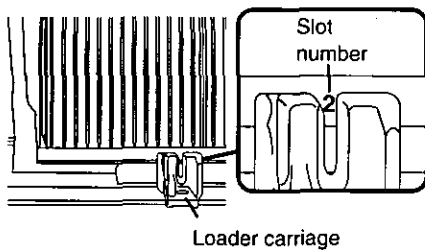

Slot No. 0 (SINGLE) is reserved for single CD play (→ page 17).

3. ① Lower the lever on the loader carriage and set the CD in the groove with the label facing to the right.

② Raise the lever.

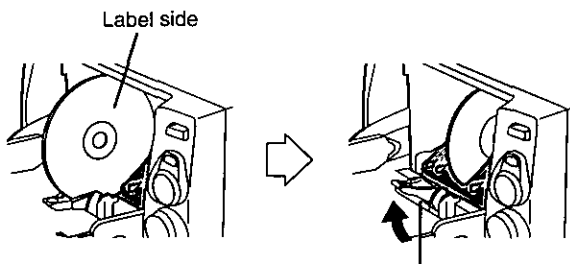

Raise the lever.

4. Close the rack panel gently.

You will hear a catching sound when the rack panel closes.

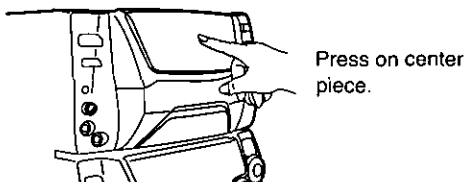

Press on center piece.

How to remove CDs

1. Open the rack panel.

2. Slide the loader carriage to the slot you want.

Note

Do not slide the loader carriage when the lever is down.

3. Push the end of lever down.

The CD rolls out into the loader carriage. Remove the CD now.

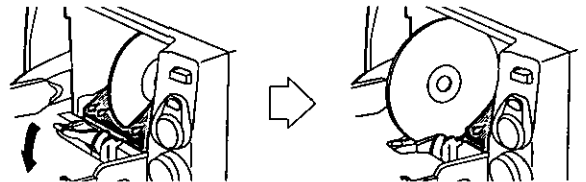

To prevent damage

Always observe the following points.

- Never load more than one CD in any given slot.
- Do not use 3" (8 cm) CDs fitted with expander rings.
- Do not put anything other than CDs in the changer.
- Do not set a CD in the slot of the CD being played (slot flashes).
- Sometimes the rack panel cannot be opened while a CD is playing. Wait until it can.
- Do not open the CD front panel and press the eject button when "SEARCH" appears in the display.
- Do not use cleaning CDs or CDs which are badly warped or cracked.
- Set the system on a flat, level surface. Do not set it on top of magazines, inclined surfaces, etc.
- Always unload all CDs before moving the system.
- Do not use CDs with poorly attached labels or stickers. Adhesive protruding from underneath stickers or left over from peeled off stickers can cause the system to malfunction.
- Do not use irregular shape CDs.

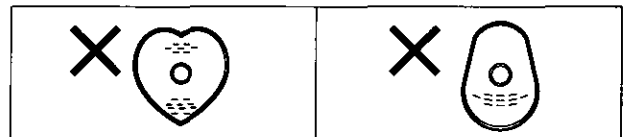

Listening to CDs

Sequential play

- 1** Press CD.
The power will come on automatically.
- 2** Set CDs in the rack.
(→ page 14 for details)
- 3** Press DISC/TRACK to select the CD selection mode.
(The indicator illuminates with a green color.)
- 4** Turn JOG to select the desired CD number.
- 5** While the CD number is flashing (approx. 10 seconds)
Press ►/||/∧. (Play will begin.)
The changer will play all CDs up through the one before the CD you started with, and it will stop automatically after playing the last track on it.

Note

If you selected an empty slot in step 4, the changer will search for the next slot with a CD in it and sequential play will begin from there.

- 6** Adjust the volume level.

To stop the CD play

Press ■.

To select a disc with the remote control

- ① Press DISC.
- ② while "—" is flashing (approx. 10 seconds)
Press the numeric button(s) to select the desired CD.

To select a two-digit CD

Press ≥10 and then the two numbers you want within 10 seconds or so.

For example

CD no. 20: ≥10→2→0

CD no. 35: ≥10→3→5

When "►" appears on the display

This indicates there are 13 or more tracks on the disc in the play position.

To pause	Press ►/ /∧ during playback. To resume playback, press ►/ /∧.
To search forward/backward (Search)	Hold down ◀◀/▶▶ (backward) or ▶▶/▶▶ (forward) during playback or pause mode.
To skip forward/backward	Press ◀◀/▶▶ (backward) or ▶▶/▶▶ (forward) during playback or pause mode.

Note

- If you leave the front panel open while a CD is playing, the changer will stop when the CD finishes.
- During random play (→ page 17), you cannot skip to tracks which have already been played.
- During program play (→ page 18) or random play, you can search forward or backward only within the current track.
- During program play, skipping is always in the programmed order, whether forward or backward.

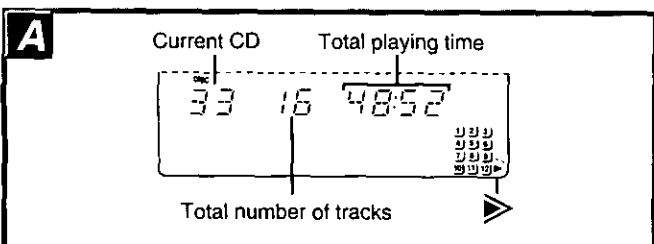
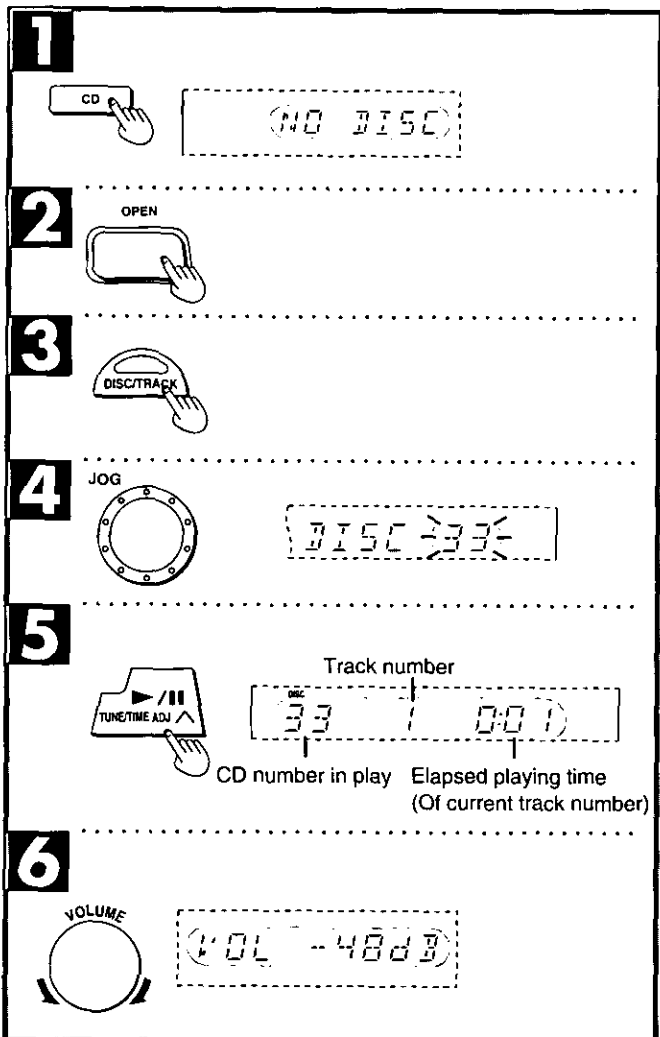
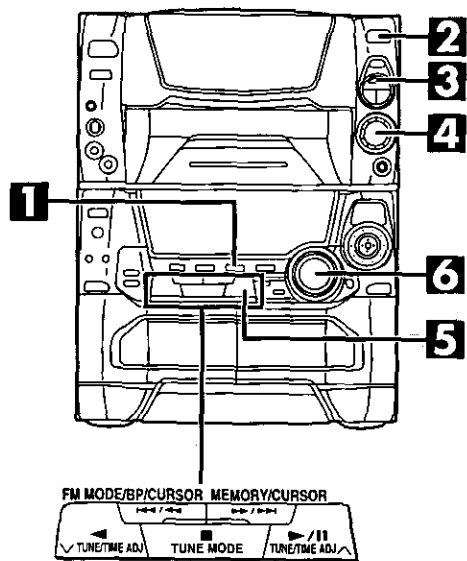

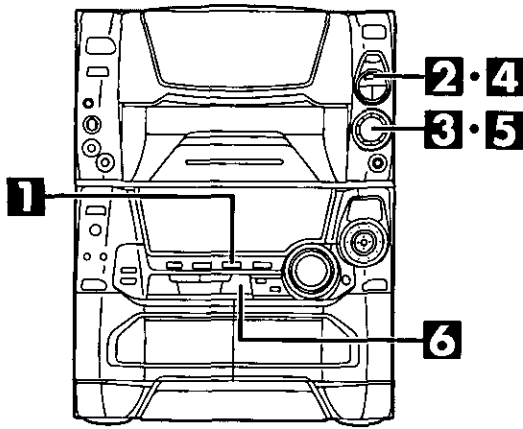

Direct access play

- 1** Press CD.
- 2** Press DISC/TRACK to select the CD selection mode.
(The indicator illuminates with a green color.)
- 3** Turn JOG to select the desired CD number.
- 4** While the CD number is flashing (approx. 10 seconds) Press DISC/TRACK to select the track selection mode.
(The indicator illuminates with an orange color.)
- 5** While the track number is flashing (approx. 10 seconds) Turn JOG to select the desired track number.
- 6** While the track number is flashing (approx. 10 seconds) Press ►/||/▲.
The CD will be played from the selected track.

To stop the CD play

Press ■.

To select a disc/track with the remote control

- ① Press DISC.
- ② While "—" is flashing (approx. 10 seconds) Press the numeric button(s) to select the desired CD.
- ③ Press the numeric button(s) to select the track.

To select a two-digit track

Press ≥10 and then the two numbers you want within 10 seconds or so.

For example

Track no. 20: ≥10→2→0

Track no. 35: ≥10→3→5

1		
2		
3	JOG	
4		
5	JOG	
6		

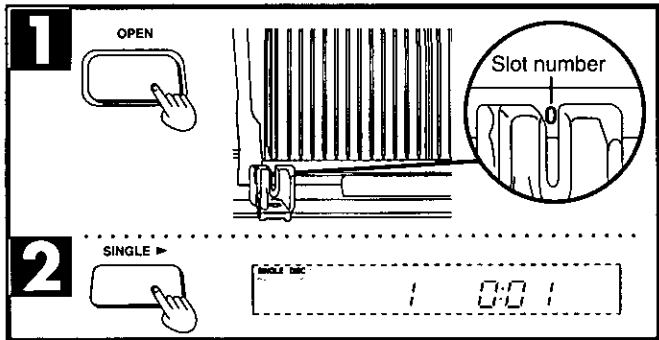
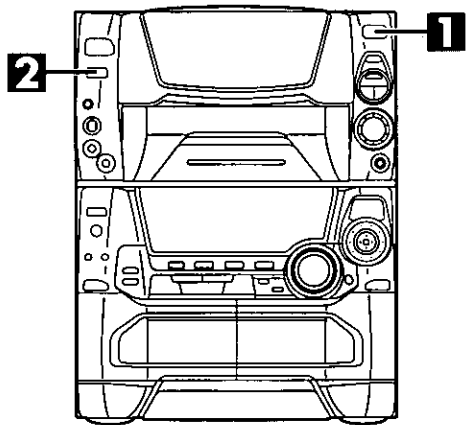
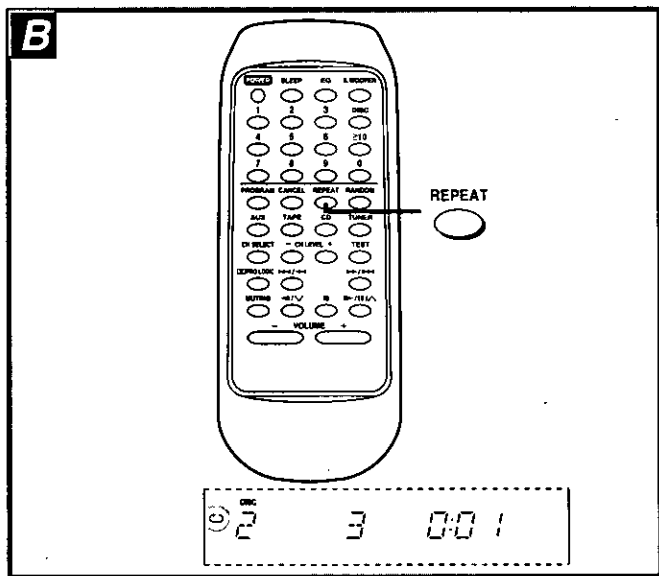
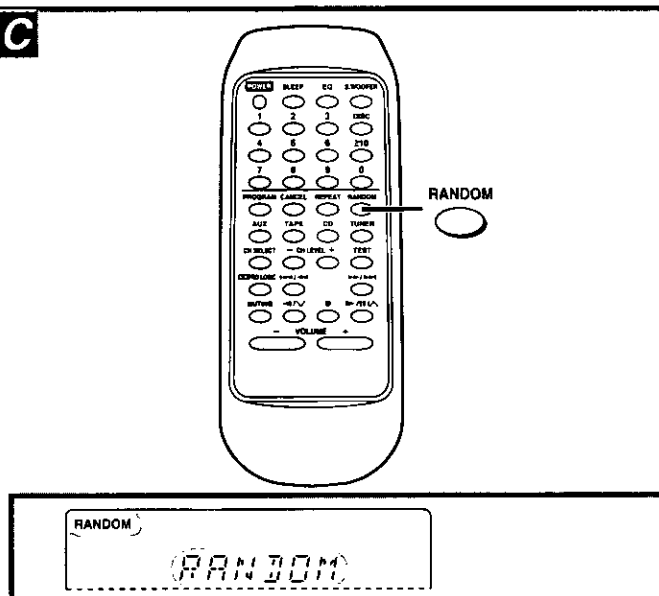
A**B****C**

Listening to CDs

Single CD play

Single CD play is for that special CD of yours, perhaps one you just bought. The changer has a slot for one special CD which you can use even when the rack is full (max. 50 CDs).

1 Press **OPEN** to open the rack panel, and set the CD in slot No. 0.

2 Close the rack panel and press **SINGLE ▶**. The CD in the slot No. 0 will be played from the first track to the last.

For your reference

While "SINGLE" appears on the display, you can start play from the ▶ button as well as the SINGLE ▶ button.

Repeat play

by remote control only

Press **REPEAT** before or during play. All tracks on the loaded CDs are repeated.

To cancel repeat play

Press **REPEAT** once again.

To repeat your favorite tracks

1. Program the tracks you want (⇒ page 18).
2. Press **REPEAT** and make sure "↻" is displayed.
3. Press ▶/||/⏏. Playback will start.

To repeat just one track

Set the 1-TRACK mode (⇒ page 20), press **REPEAT** before or during playback, and make sure "↻" is displayed.

To repeat all tracks on a specific CD

Set the 1-DISC mode (⇒ page 20), press **REPEAT** before or during playback, and make sure "↻" is displayed.

Random play

by remote control only

Press **RANDOM**.

All tracks on the loaded CDs will be played in random order. Playback will stop automatically when a maximum of 72 tracks from the loaded CDs have been played.

To cancel random play

Press **RANDOM** once again.

For random play with just one specific CD

Set the 1-DISC mode (⇒ page 20) and press **RANDOM**.

Note

- You can use random play with your program. Only the programmed tracks will be played, but in random order.
- Once more than 25 tracks have been played in random mode, a track may be played again.

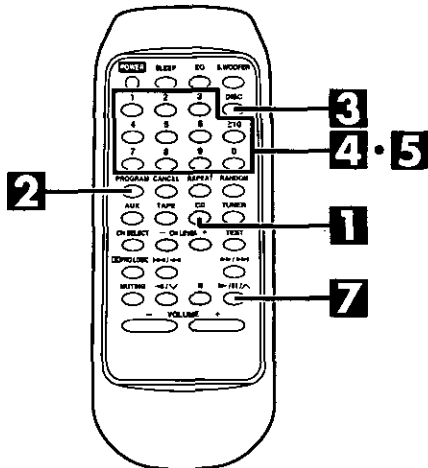

1 CD

2 PROGRAM

3 DISC

4 Specified disc number

5 Specified track number Program order

7

A PROGRAM

Listening to CDs

Program play

by remote control only

- Everyone has their favorite tracks. You can program the changer to play them in a specific order. With this changer, you can make one program and fill it with up to 24 selections from any of the CDs in the rack.
- You can also program a certain track during playback. (See "Direct programming" below.)

- 1 Press CD.**
Ensure CD is stopped.
- 2 Press PROGRAM.**
- 3 Press DISC.**
- 4** While "—" is flashing (approx. 10 seconds)
Select the CD(s) you want with the numeric button(s).
You can select slot No. 0.
"SINGLE" appears on the display.
- 5 Press the numeric button(s) to select the desired track.**
- 6 Repeat steps 3 through 5 until you have programmed all the tracks you want.**
- 7 Press ►/||/▲.**
Play will start in the programmed sequence.

Direct programming

If, while listening to a certain track, you decide that you want to program that track to your program, you can with direct programming.

[While the track you want to program is playing]

Press PROGRAM.
The display will return to the original indication after about 3 seconds.

When you make a program as explained under "Program play" above, and then perform this procedure without clearing the program first, the selected track is added to the end of the program. To listen to programmed tracks, press PROGRAM and check "PRGM" appears on the display, then press ►.

Note
During program play, the PROGRAM button does not operate.

(Continued on next page)

Listening to CDs

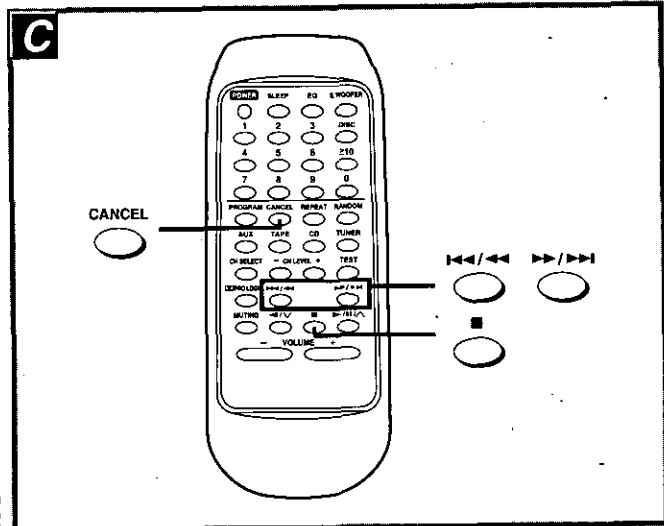
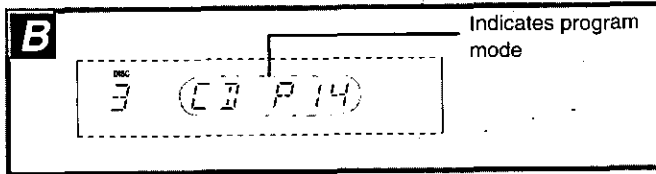

To cancel program play mode

Press **PROGRAM** in the stop mode.

Programmed contents will be saved in memory.

Pressing **■** will cancel program play, but it will also erase the entire program.

To select a two-digit track

Press ≥ 10 and then the two numbers you want.

For example

Track no. 20: $\geq 10 \rightarrow 2 \rightarrow 0$

Track no. 35: $\geq 10 \rightarrow 3 \rightarrow 5$

When "CD FULL" appears **A**

The number of programmed tracks is limited to 24. No further tracks can be programmed.

You can do the following while stopped during program mode **B**

• Check program contents.

Press **◀◀/◀◀** or **▶▶/▶▶**.

Everytime you press one of the buttons, the track and program No. are shown on the display.

• Add to the program.

Repeat steps 3 through 5.

• Cancel entries. **C**

From the last programmed track	Press CANCEL .
A specified track only	Select the track with ◀◀/◀◀ or ▶▶/▶▶ , and press CANCEL within 3 seconds.
All tracks	Press ■ .

Memory retention

Your program is retained in memory for about 2 weeks while the system is unplugged.

To replay your program

If you turned OFF your program with **PROGRAM**, you can play it again.

1. Press **PROGRAM**.
2. Press **▶/||/∧**.

If you program a track not on your CDs

The track is initially programmed, but during program play, the changer will skip that track and will continue playing from the next programmed item.

To listen to special CDs and tracks (CD MANAGER function)

This function makes it easier for you to select special CDs and tracks from amongst those loaded in the player.

You can use this function to make recordings as well. (⇒ page 35)

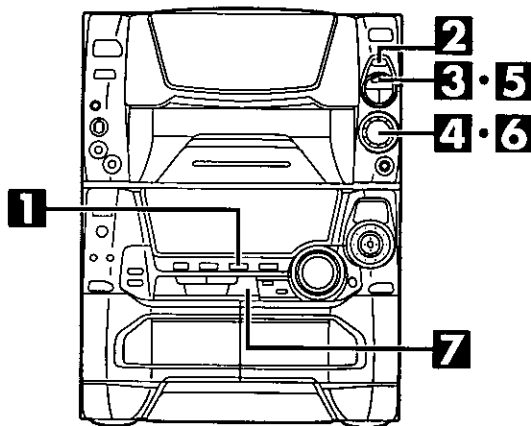

- 1 Press CD.**
Ensure CD is stopped.
- 2 Press CD MANAGER to select the desired mode.**

Every time you press the button;

1-TRACK → 1-DISC → 1-ALL
 ↑ NORMAL ↓
 (OFF)

- 1-TRACK: Only one particular track is played.
 - 1-DISC: The tracks on only one particular disc are played.
 - 1-ALL: The same track numbers on each of the CDs are played in succession.
- (NORMAL: The original display is restored in about 3 seconds.)

- 3 Press DISC/TRACK to select the CD selection mode.**

(The indicator illuminates with a green color.)

- 4 Turn JOG to select the desired CD number.**

Note

This step is not required if 1-ALL was selected in step 2.

- 5 Press DISC/TRACK to select the track selection mode.**

(The indicator illuminates with an orange color.)

- 6 Turn JOG to select the desired track number.**

Note

This step is not required if 1-DISC was selected in step 2.

- 7 Press /||/▲.**

The selected track will start.

To stop play

Press ■.

When playback ends

"NORMAL" will appear on the display for about 3 seconds, then the CD MANAGER function will turn OFF automatically.

During play in the 1-ALL mode:

- It is not possible to skip back to a CD whose track has already been played.
- If a CD does not have the designated track number, it is skipped and play continues.

Note

You can use the repeat function (⇒ page 17) and random play (⇒ page 17) at the same time. However, in 1-TRACK mode, random play is not available.

CD-TEXT function

This convenient function displays the names of albums and tracks for you. The function also works for normal discs, not just discs that have the information installed on them (CD-TEXT discs).

Note

- Names of tracks cannot be displayed with normal CDs.
- The information on CD-TEXT discs is automatically read when play starts. With normal discs it is necessary to enter the album name manually. Enter the information before playing the disc (⇒ page 23).

To see the name of the CD or track

Press TEXT MODE.

The name of the CD or track scrolls across the screen in the following ways each time the button is pressed.

In the stop mode **A**

Album title → Total playing time

In the play mode **B**

Song title → Album title
 ↑ Elapsed playing time (of current track) ←

Note

- In the stop mode up to 32 characters per piece of information will be displayed. During play, the album title or song title is displayed in its entirety even if it is longer than 32 characters.
- Song titles are not displayed after a certain number of tracks if there are many tracks on the disc or if titles are exceptionally long.
- If you search during play, the display automatically switches to show the elapsed time.
- If you skip during play, the name of the track scrolls across the screen, then the display switches back to the previous display.
- Information that has been entered will be stored in the memory until either a different CD-TEXT disc is played or the album name is changed manually (⇒ page 23).

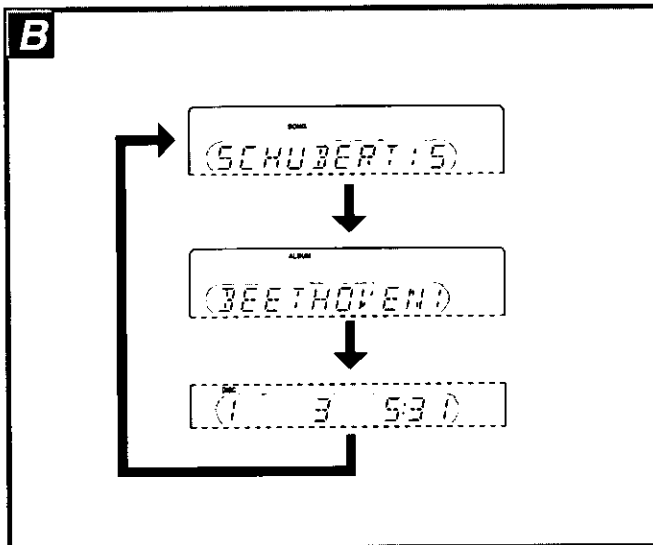
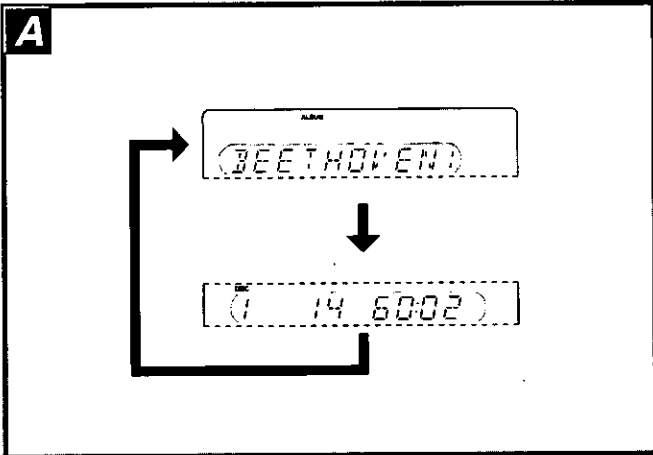
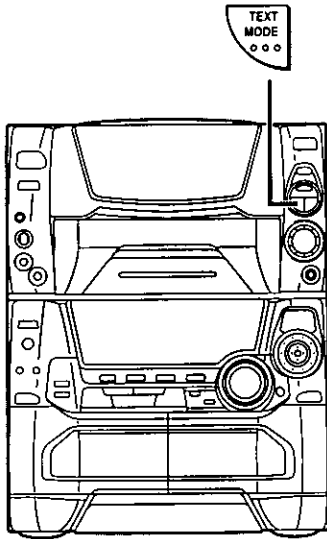

A

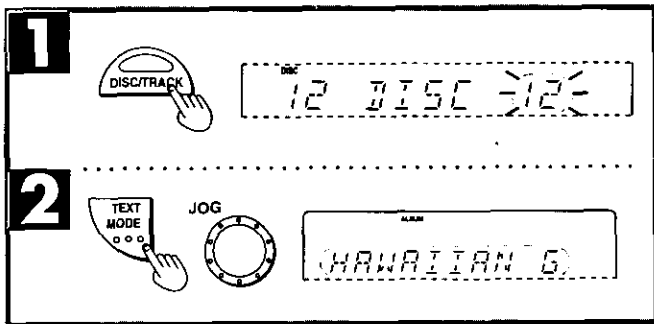
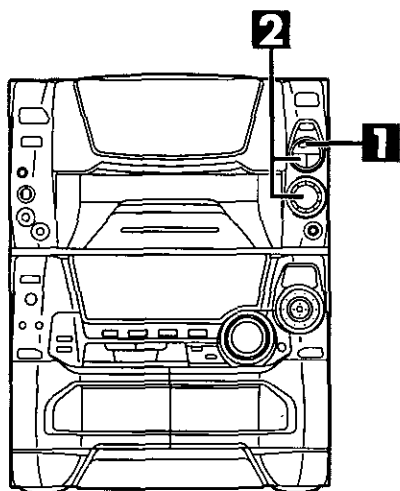

B

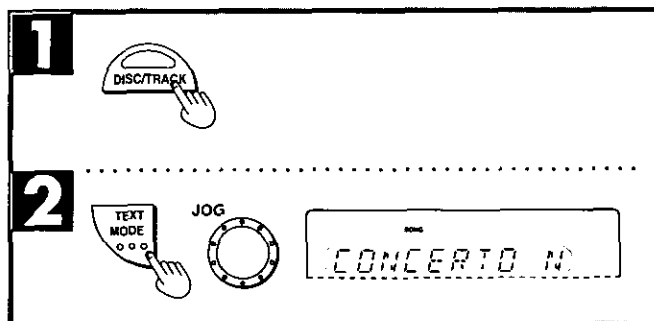
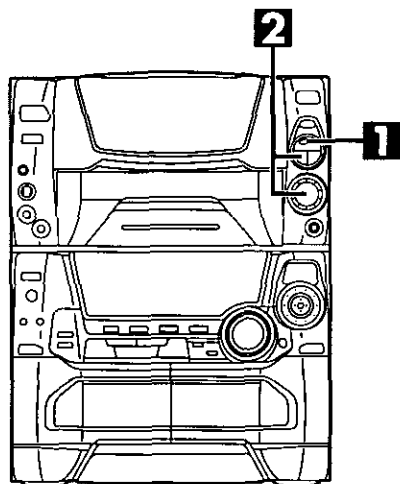

Listening to CDs

CD-TEXT function

To find a specific CD (Album search) 

If the information for an album is in the memory, you can search for it by name.

1 Press DISC/TRACK to select the CD selection mode.

(The indicator illuminates with a green color.)

2 Press TEXT MODE to select "ALBUM", and turn JOG to select the desired album title.

To playback the CD

Press ►/||/∧ before the album name stops flashing.

To find a specific song (Song search) 

Note

This function only works with a CD-TEXT disc that is currently playing.

1 Press DISC/TRACK to select the track selection mode.

(The indicator illuminates with an orange color.)

2 Press TEXT MODE to select "SONG", and turn JOG to select the desired song title.

To playback the song

Press ►/||/∧ before the song name stops flashing.

Listening to CDs

CD-TEXT function

To name a CD

You can enter an album name containing up to 32 characters for each of the CDs in the changer.

1 In the stop mode
Press **DISC/TRACK** to select the CD selection mode.
(The indicator illuminates with a green color.)

2 Select the disc you want to name by turning **JOG**.

3 While the CD number is flashing (approx. 10 seconds)
Press **TEXT EDIT**.
The cursor will start flashing when the changer is in the text edit mode.

4 Turn **JOG** to select the first character.
Select from the following letters and symbols.
A B C D E F G H I J K L M N O P Q R S T U V W X Y Z
(space)
! " # \$ % & ' () * + , - . / 0 1 2 3 4 5 6 7 8 9 : ; < = > ? @

Note

- "A" is displayed when JOG is first turned, then the characters change in the above order.
- Letters and symbols appearing on the display may vary slightly from the printed listing.

5 Press **▶▶/▶▶I**.
This enters the selected character and moves the cursor to the next character space.

6 Repeat steps 4 and 5 to enter characters.

7 Press **TEXT EDIT**.
(The album name is entered into memory and the changer goes out of text edit mode.)
The album name you entered flashes for 10 seconds then the display returns to the mode it was in previous to this operation.

Note

If you press **■** during text edit mode, the characters that were entered will be cleared and the changer will return to the previous mode.

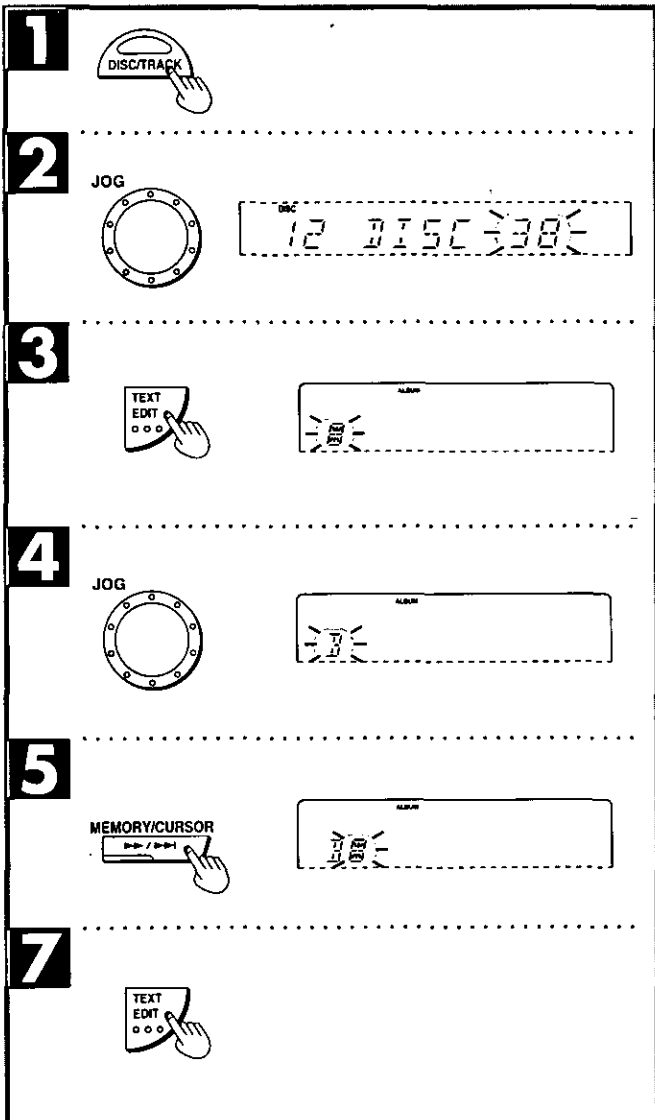
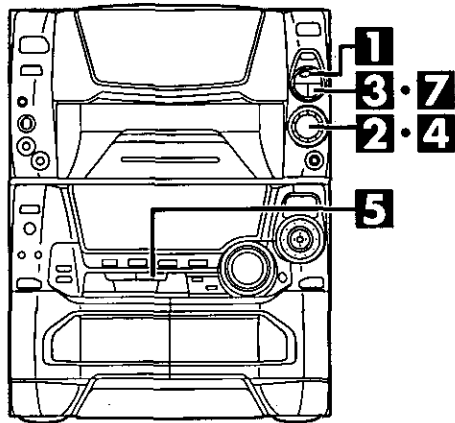

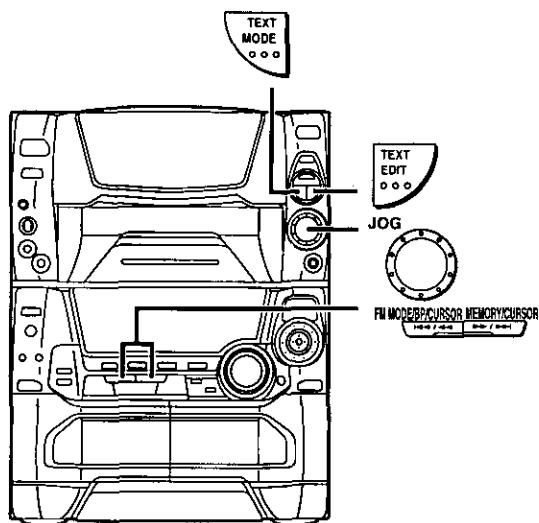

Listening to CDs

CD-TEXT function

To change an album name you have entered

- 1** Turn JOG to select the album title to be changed.
- 2** While the album title is flashing
Press **TEXT EDIT**.
The first character flashes.
- 3** Press **◀◀/▶▶** or **▶▶/▶▶** to select the character you want to change.
- 4** Turn JOG to select the new character.
- 5** Press **TEXT EDIT**.

To clear an album name you have entered

- 1** Turn JOG to select the album title to be cleared.
- 2** While the album title is flashing
Press **TEXT EDIT**.
- 3** Press **TEXT MODE** for about 5 seconds.
"TEXT CLEAR" appears on the display and the album name is cleared.

Listening to tapes

Types of tapes which can be played correctly:
The unit automatically identifies the type of tape.

NORMAL POSITION/TYPE I	<input type="radio"/>
HIGH POSITION/TYPE II	<input type="radio"/>
METAL POSITION/TYPE IV	<input type="radio"/>

You can use either deck 1 or deck 2 for tape playback.

- 1 Press TAPE.**
The power will come on automatically.
- 2 Press DECK 1 ▲ OPEN or DECK 2 ▲ OPEN and insert the tape.**
Insert the tape with the exposed tape facing down.
Close the holder by hand.
- 3 Press REV MODE to select the reverse mode.**
Every time you press the button;
 - : One side is played, then playback stops automatically.
 - : Both sides (front side—reverse side) are played one time each, then playback stops automatically.
 - : Both sides are played 8 times each, then playback stops automatically.
- 4 Press ◀ or ▶ to start playback.**
 - ▶: The forward side (front side) will play.
 - ◀: The reverse side will play.
- 5 Adjust the volume level.**

To stop tape playback

Press ■.

To change the deck to be used

Press TAPE DECK 1/2 to select the deck you want to use when you load cassettes into both decks.

To listen to 2 tapes consecutively

Load a tape into each deck and select . Both tapes will be played 8 times each.

Note

Playback is interrupted while playing back tapes, if you open the other deck.

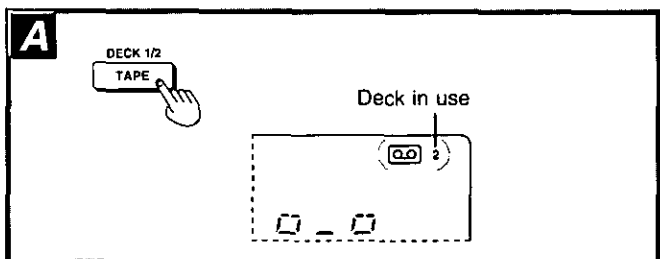
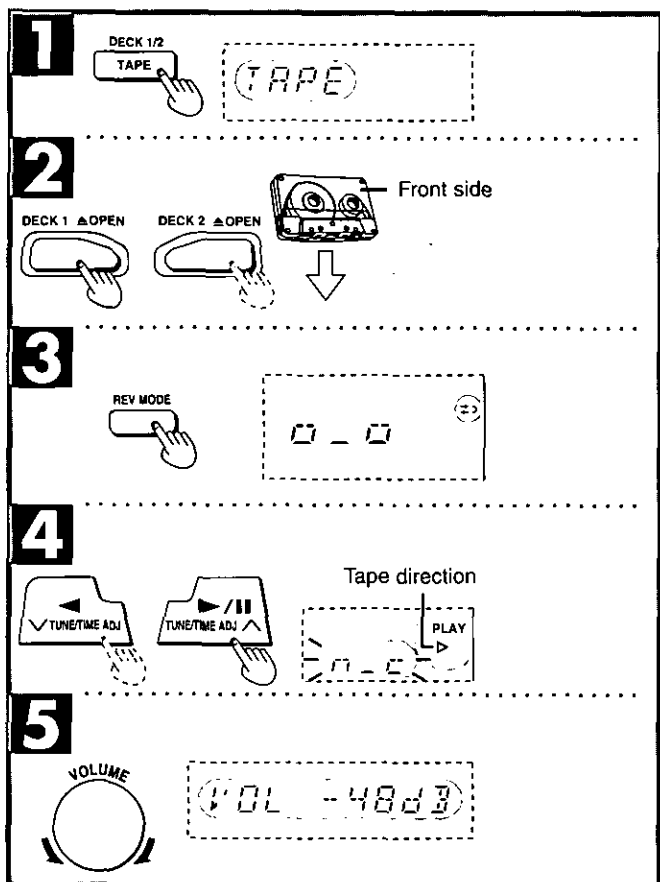
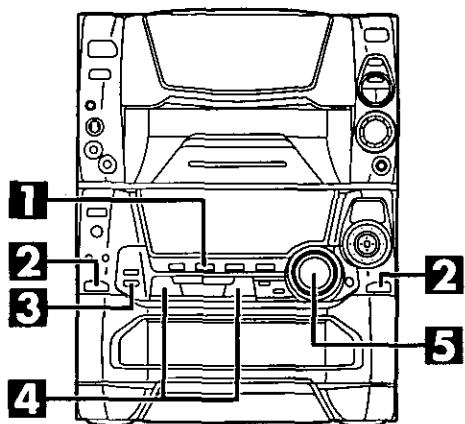

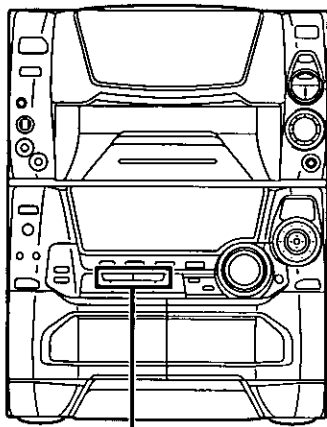

FM MODE/BP/CURSOR MEMORY/CURSOR
 ◀◀ / ▶▶ ▶▶ / ▶▶▶▶

Listening to tapes

To fast-forward or rewind the tape

Press ◀◀/▶▶ or ▶▶▶▶ in the stop mode.

Tape direction	To rewind	To fast-forward
"▶"	◀◀/▶▶	▶▶▶▶
"◀"	▶▶▶▶	◀◀/▶▶

To find the beginning of a program (TPS: Tape Program Sensor)

Press ◀◀/▶▶ or ▶▶▶▶ during play.

Tape direction	To play the current tune from the beginning	To play the next tune from the beginning
"▶"	◀◀/▶▶	▶▶▶▶
"◀"	▶▶▶▶	◀◀/▶▶

Note

The TPS function searches for silent parts of about 4 seconds in length which are normally found between tunes. As a result, it may not function properly in the following cases

- With short silent parts
- When noise occurs between tunes
- With silent parts found within tunes

Using the built-in sound quality/ sound field settings

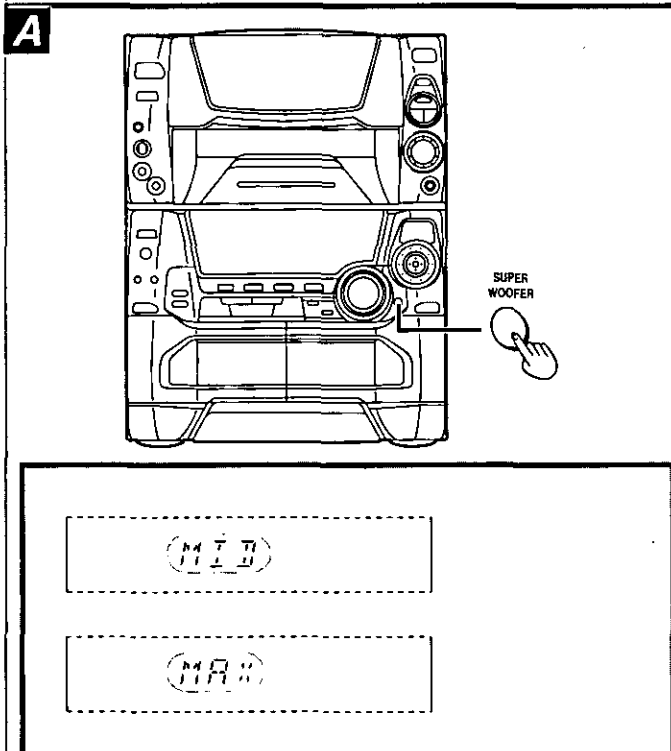
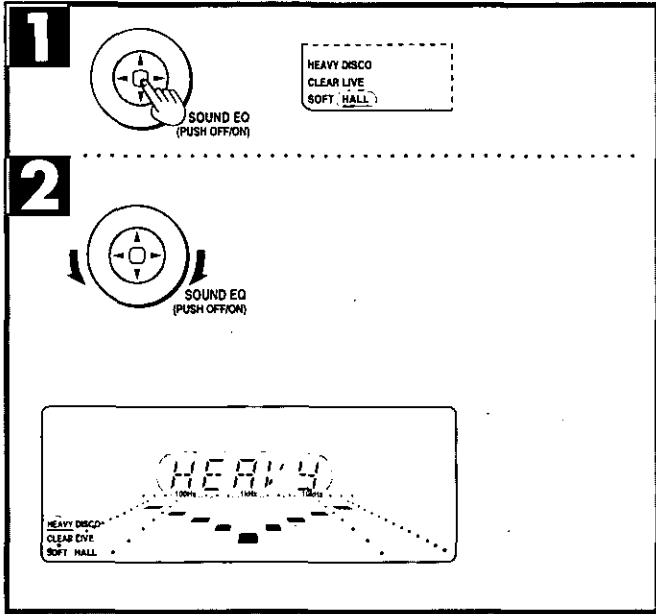
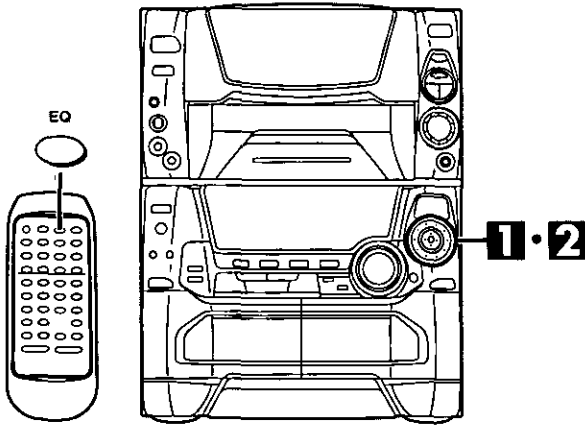

1 Press the SOUND EQ joystick to turn on the equalizer.
The SOUND EQ lamp lights more brightly, and "FLAT" is cleared.

2 Dial SOUND EQ to select the sound quality or sound field.

When it is turned clockwise, the settings are selected in the following sequence.

- ① **HEAVY (sound quality)**
Select this when playing rock or other kinds of music that sound better with an added punch.
 - ② **CLEAR (sound quality)**
Select this for jazz or other kinds of music for which clarity in the treble range is desired.
 - ③ **SOFT (sound quality)**
Select this when listening to background music.
 - ④ **DISCO (sound field)**
Select this to produce sound with the same kind of lengthy reverberations heard at a disco.
 - ⑤ **LIVE (sound field)**
Select this to make vocals more alive.
 - ⑥ **HALL (sound field)**
Select this to add an expansiveness to the sound to produce the atmosphere of a great concert hall.
 - ⑦ **MANUAL (= page 29)**
 - ⑧ **AI EQ (= page 28)**
- The original display is restored on the display panel in about 5 seconds. The sound quality/sound field setting can be changed as long as SOUND EQ is on.

To release the equalizer

Press the SOUND EQ joystick so that "FLAT" is displayed.

When using the remote control to perform the operations described above

Press EQ.

Each time this button is pressed, the setting is changed in the sequence given in step 2. Note that after "MANUAL" is displayed, "FLAT" is selected.

Boosting the super woofer

Press SUPER.WOOFER.

- When listening to the sound through the speakers
MID (medium) → MAX (high) → Light off (OFF)
- When listening to the sound through the headphones
Light on (ON) ↔ Light off (OFF)

Note

All recordings are performed at the flat setting even if an alternative sound quality/sound field setting has been selected and the super woofer effect is set to ON.

Varying the sound quality with the acoustic image (AI) equalizer

The AI equalizer uses the SOFT, SHARP, HEAVY and LIGHT sound quality coordinates to achieve subtle sound quality settings with ease.

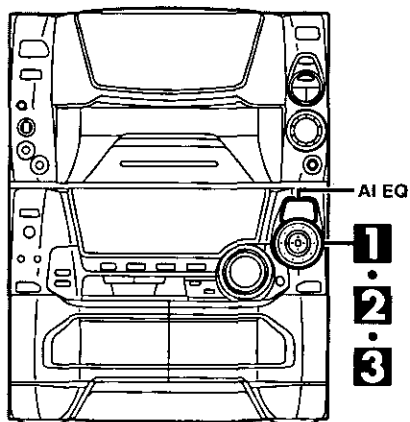

1 Press the SOUND EQ joystick to turn on the equalizer.

The SOUND EQ lamp lights more brightly, and "FLAT" is cleared.

2 Dial SOUND EQ to display "AI EQ".

When it is turned clockwise, the settings are selected in the following sequence.

- ① HEAVY
- ② CLEAR
- ③ SOFT
- ④ DISCO
- ⑤ LIVE
- ⑥ HALL
- ⑦ MANUAL
- ⑧ AI EQ

3 Operate the SOUND EQ joystick and set the sound quality as desired.

- ① ← → direction: SOFT–SHARP setting
- ② ↓ ↑ direction: LIGHT–HEAVY setting

Repeat steps ① and ② to set the desired sound quality.

The original display is restored on the display panel in about 5 seconds. Only one AI EQ lamp lights to give a rough indication of the coordinate position.

The sound quality can be re-selected using SOUND EQ while the lamp is alight.

To release the equalizer

Press SOUND EQ joystick so that "FLAT" is displayed.

Note

- The sound quality setting is stored automatically. It is recalled when "AI EQ" is next selected.
- All recordings are performed at the flat setting even if an alternative sound quality setting has been selected.

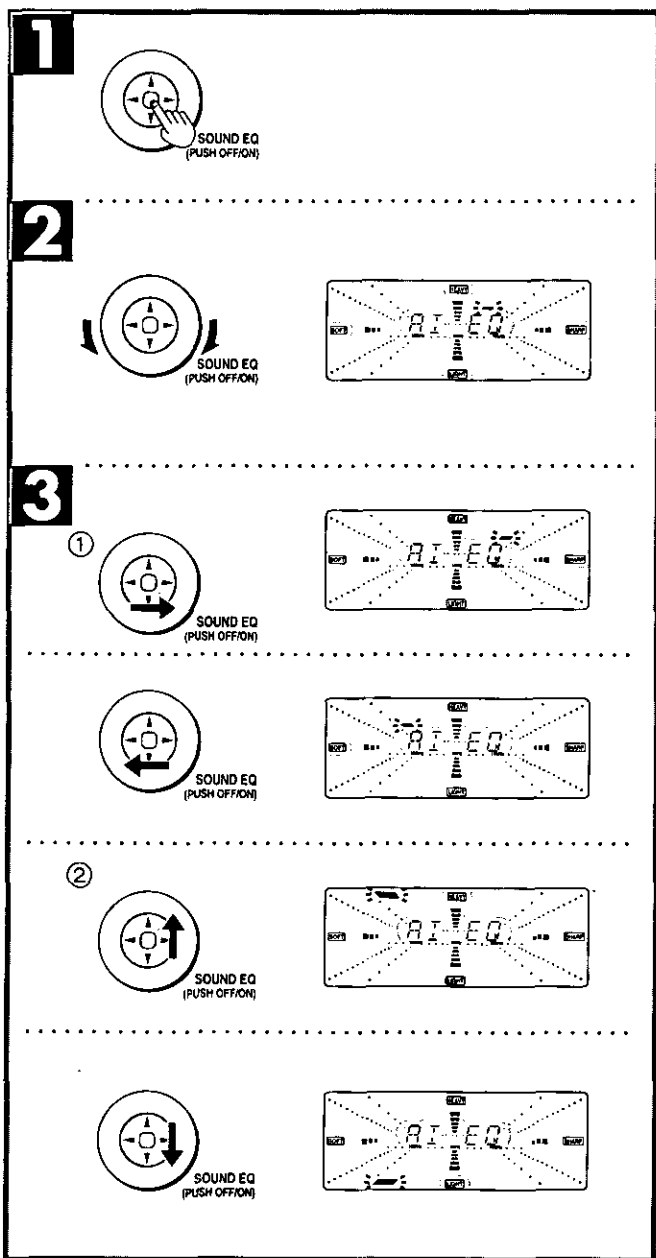

Varying the sound quality with the manual equalizer

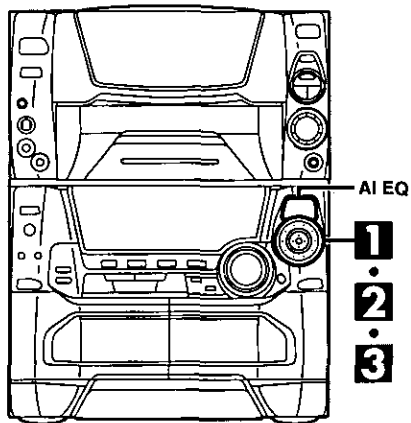

1 Press the SOUND EQ joystick to turn on the equalizer.

The SOUND EQ lamp lights more brightly, and "FLAT" is cleared.

2 Dial SOUND EQ to display "MANUAL".

When it is turned clockwise, the settings are selected in the following sequence.

- ① HEAVY
- ② CLEAR
- ③ SOFT
- ④ DISCO
- ⑤ LIVE
- ⑥ HALL
- ⑦ **MANUAL**
- ⑧ AI EQ

3 Operate the SOUND EQ joystick and set the sound quality as desired.

① ← → direction: For selecting the range of the sound to be adjusted

Characteristics of each sound range

Under 100 Hz: Super woofer range

Around 330 Hz: Bass to midrange

Around 1 kHz: Midrange

Around 3.3 kHz: Midrange to treble

Above 10 kHz: Treble

② ↓ ↑ direction: For adjusting the level (7 steps)

When the level is in the center, the dot flashes more rapidly.

Repeat steps ① and ② to set the desired sound quality.

The original display is restored on the display panel in about 5 seconds. When the manual equalizer is ON, all four AI EQ lamps light.

The sound quality can be re-selected using SOUND EQ while the lamp is alight.

To release the equalizer

Press the SOUND EQ joystick so that "FLAT" is displayed.

Note

- The sound quality setting is stored automatically. It is recalled when "MANUAL" is next selected.
- All recordings are performed at the flat setting even if an alternative sound quality setting has been selected.

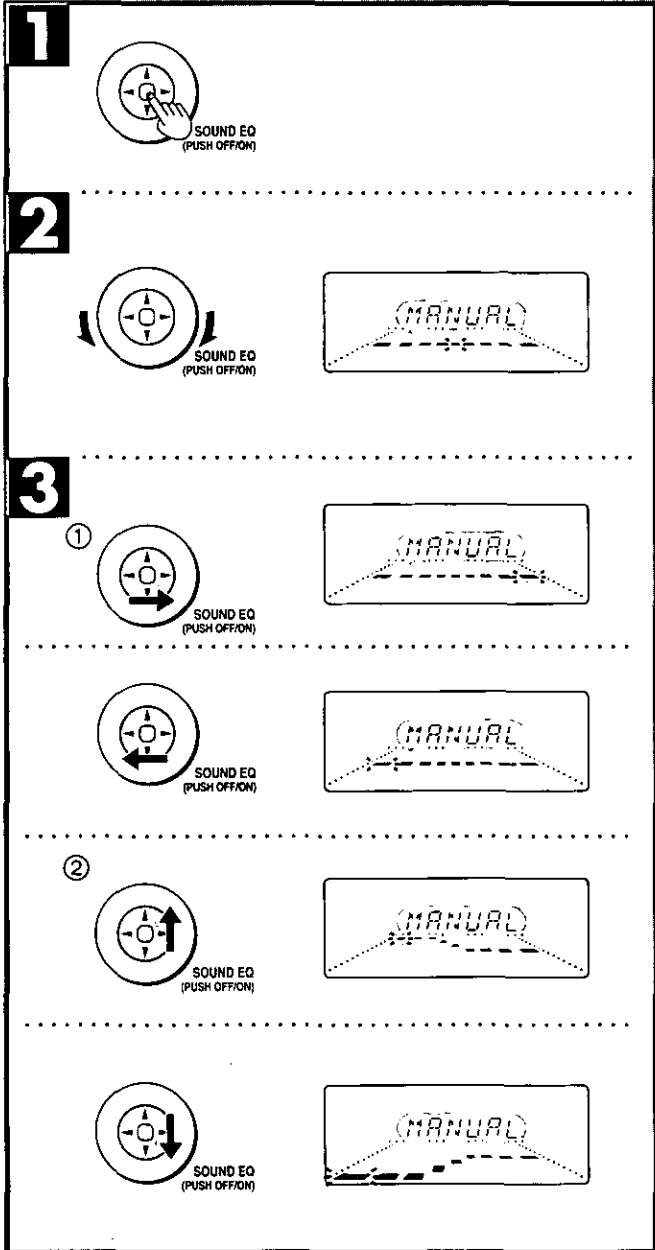

Enjoying sound with DOLBY PRO LOGIC

SC-AK95 only

Dolby Pro Logic lets you enjoy movie software (video tapes and laser discs) in your home with the same powerful stereophonic effect found in movie theaters.

Manufactured under license from Dolby Laboratories Licensing Corporation.

DOLBY, the double-D symbol  and "PRO LOGIC" are trademarks of Dolby Laboratories Licensing Corporation.

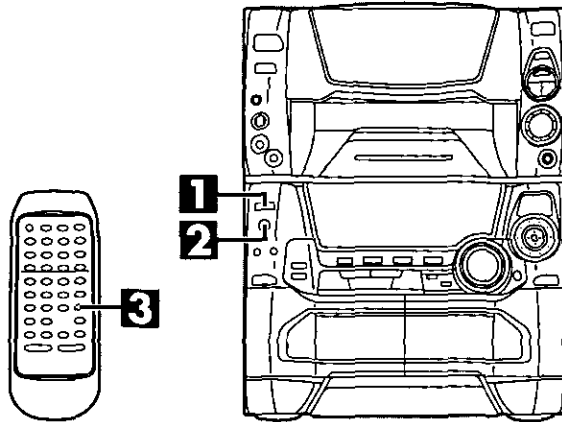

Setting the center mode and adjusting speaker output level

Note

Do the adjustments from the position where you would normally be listening.

1 Press DOLBY PRO LOGIC to turn on the DOLBY PRO LOGIC system.

The button lights up.
Press once again to turn it off.

2 Press CENTER MODE to select "NORMAL".

When the button is pressed, the current center mode is displayed.
Pressing it again changes the center mode.

NORMAL

When the center speaker is smaller than the front speakers.

WIDE

When the center speaker is the same size or larger than the front speakers.

PHANTOM

When no center speaker is connected.

Note

In the PHANTOM mode, the sound which would have been sent to the center speaker is divided equally between the left and right front speakers.

3 by remote control only

Press TEST to output a test signal.

The speaker outputting the test signal is displayed while the test is running.

- L: Front speaker (Left)
- C: Center speaker
- R: Front speaker (Right)
- S: Surround speakers

In the PHANTOM mode, the center speaker is OFF, so the test signal is not output and "C" is not displayed.

(Continued on next page)

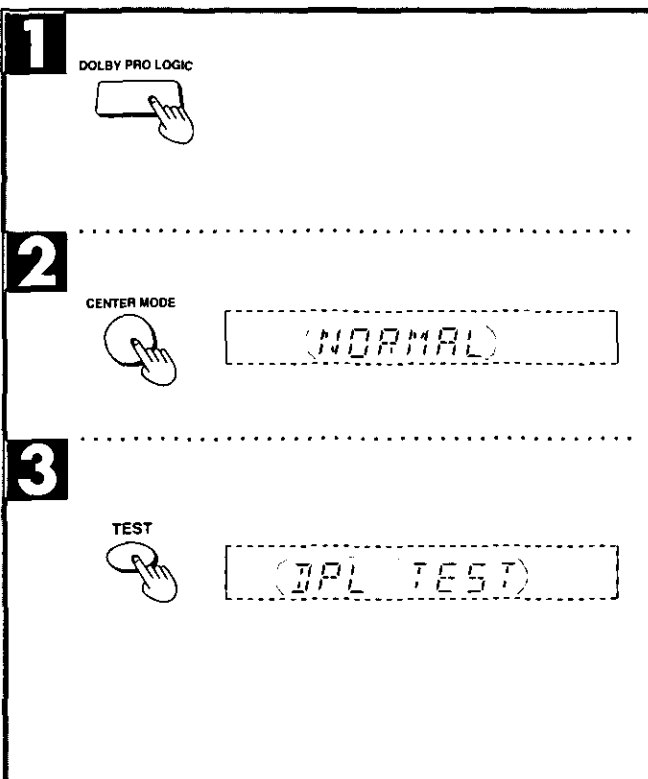

Enjoying sound with DOLBY PRO LOGIC

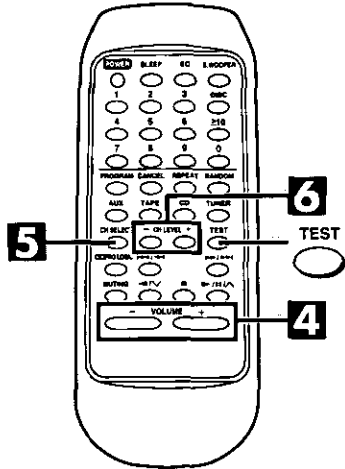

- 4** **by remote control**
Press **VOLUME (-)** or **(+)** to set the volume level normally used for enjoying the source.

The following steps are for setting the output level of the front speakers and the center/surround speakers to the same listening level.

- 5** **by remote control only**
Press **CH SELECT** to select the center or surround speakers.

- 6** **by remote control only**
Press **CH LEVEL (-)** or **(+)** to adjust the output level.

Adjust the output level of each speaker from the listening position until they are all the same.

-: Decrease the output level.

+: Increase the output level.

Output level can be varied within a range of -12 dB to +12 dB with front speaker output level serving as the zero point.

The test signal is output only by the speaker you are now adjusting and does not repeat the sequence until adjustment are complete.

To stop the test signal

Press **TEST**.

To turn off the DOLBY PRO LOGIC systems

Press **DOLBY PRO LOGIC**.

Press once again to turn it on.

Enjoying the desired source with DOLBY PRO LOGIC ^A

- 1** Press **DOLBY PRO LOGIC** to turn on the DOLBY PRO LOGIC system.

The button lights up.

Press once again to turn it off.

- 2** Select and start the desired source.

To turn off the DOLBY PRO LOGIC systems

Press **DOLBY PRO LOGIC**.

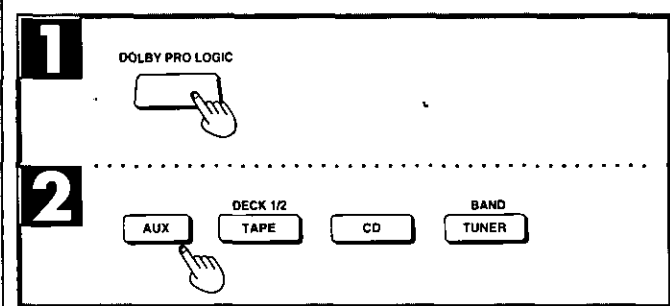
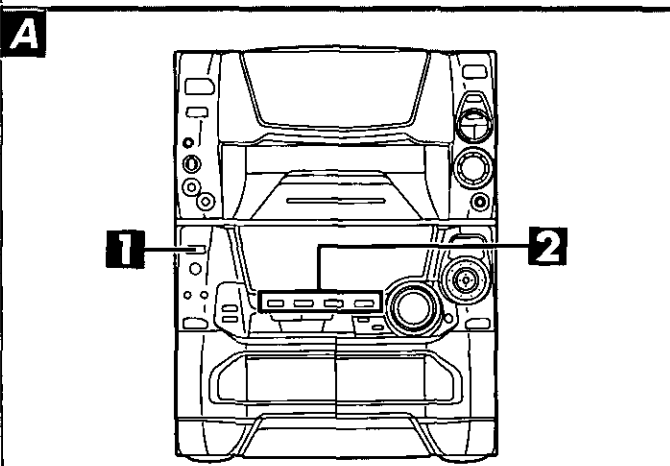
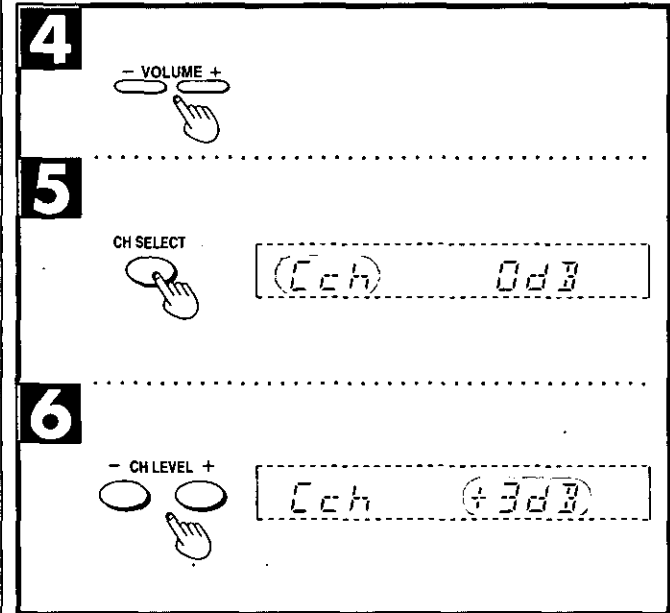

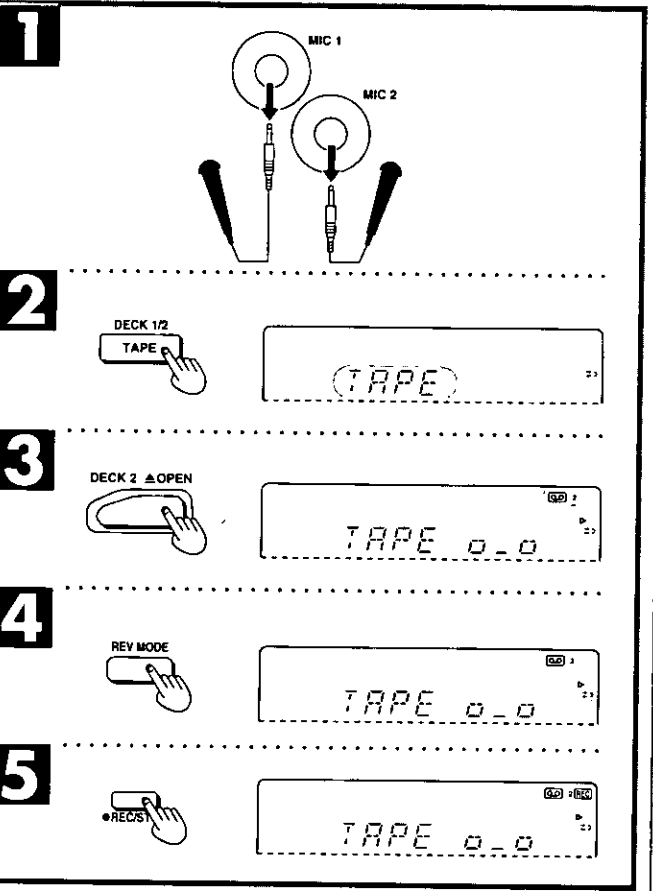
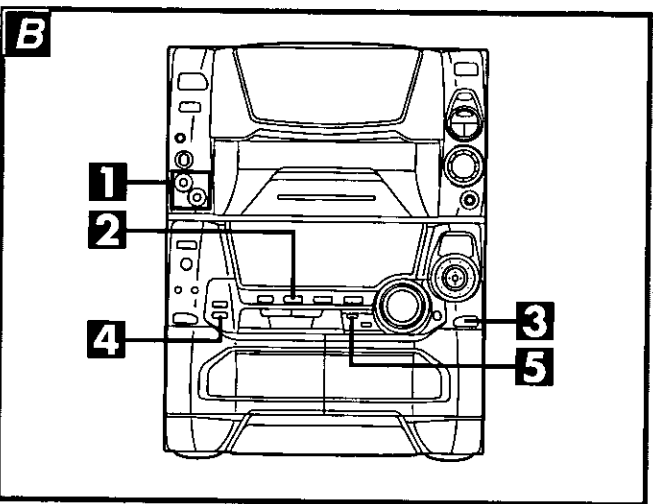
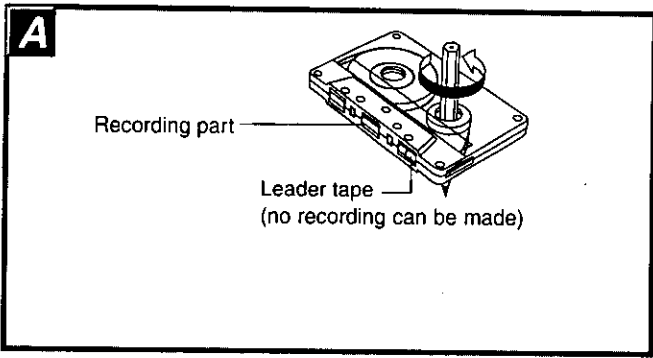

Before recording (Deck 2 only)

Types of tapes which can record correctly

The unit automatically identifies the type of tape.

NORMAL POSITION/TYPE I	○
HIGH POSITION/TYPE II	○
METAL POSITION/TYPE IV	×

This system cannot record or erase correctly if metal position tapes are used.

To record from the beginning of the tape **A**

You cannot record on the leader part of the tape. Before recording, wind the tape past the leader to a point where recording can start immediately.

How volume, sound quality/field and super woofer affect recording

The tape you are recording is not effected whatsoever by changes in volume, sound quality/field or super woofer.

- In recording, sound quality/field are set automatically to "FLAT".
- You can change volume and super woofer effect for the playback sound.

To erase a recording **B**

- 1** SC-AK95 only
Disconnect the microphone(s).
- 2** Press TAPE.
- 3** Insert the recorded tape into deck 2.
- 4** Press REV MODE to select reverse mode.
- 5** Press ● REC/STOP.

Note

- You cannot open deck 1 while recording.
- You cannot fast-forward or rewind one deck while recording with the other.

Recording from radio broadcasts

1 Press DECK 2 \blacktriangle OPEN and insert the tape.

Close the holder by hand.

Tape direction is automatically set to "▶".

2 Press REV MODE to select the reverse mode.

Every time you press the button;

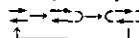

▶: One side is recorded, then recording stops automatically.

▶, ◀: Both sides (front side → reverse side) are recorded, then recording stops automatically.

3 Select a radio station.

(⇒ page 13, steps 1 to 3).

4 Press \bullet REC/STOP to start recording.

If you selected ◀ in step 2, the direction will automatically change to ▶ when recording starts.

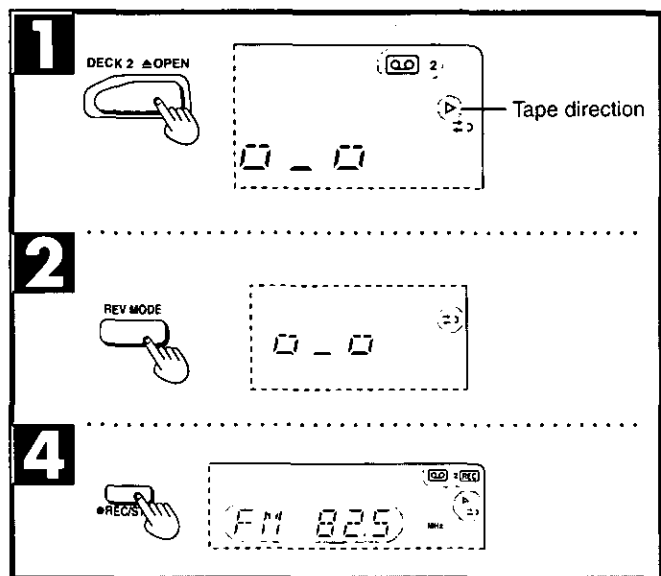
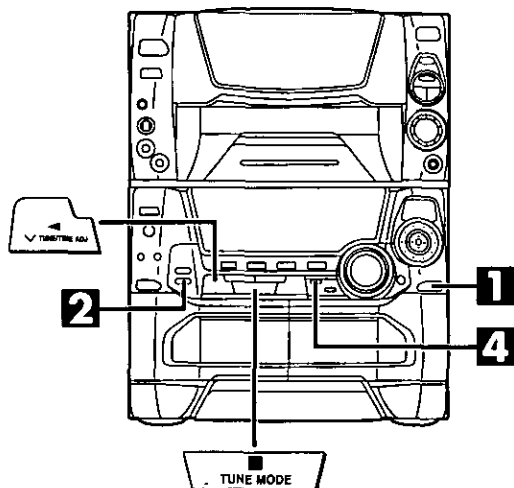

A

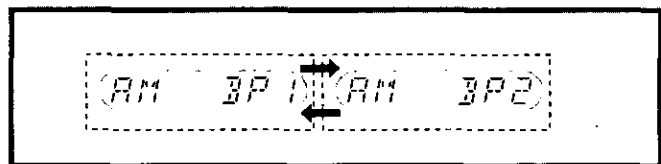
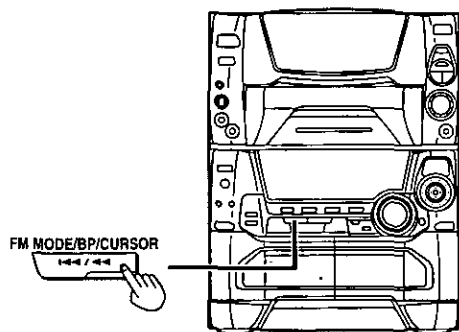

To stop recording

Press \bullet REC/STOP again.

Recording can also be stopped by pressing \blacksquare .

To start recording on the reverse side

Load a tape and change the tape direction as following.

1. Press TAPE DECK 1/2 and select tape deck 2.
2. Press \blacktriangleleft and immediately thereafter \blacksquare . The tape direction will be shown as " \blacktriangleleft ".

To record from a specific point on a tape

Before recording, advance the tape to the point from where you want to start recording.

To cut an unnecessary part while recording

1. Press \bullet REC/STOP during the unnecessary part. The cassette deck will go into the stop mode.
2. Press \bullet REC/STOP to resume recording again. Recording will continue in the same direction as before.

Note

When recording an AM broadcast, sound is momentarily interrupted when you start and stop the recording.

To reduce noise while AM recording (Beat proof function) \boxtimes

Press FM MODE/BP while recording.

Each time you press the button, BP 1 and BP 2 will be displayed alternately.

Select the position with the least noise.

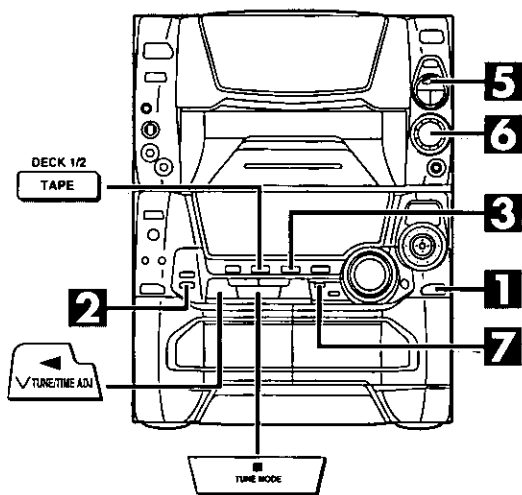

1 DECK 2 \blacktriangle OPEN

2 REV MODE

3 CD

5 DISC/TRACK

6 JOG

7 REC/STOP

Recording from CDs

- 1** Press **DECK 2 \blacktriangle OPEN**, and then insert the tape.
Close the holder by hand.
Tape direction is automatically set to "▶".
- 2** Press **REV MODE** to select the reverse mode.
Every time you press the button;
 - ▶: One side is recorded, then recording stops automatically.
 - ↔, ◀▶: Both sides (front side→reverse side) are recorded, then recording stops automatically.
- 3** Press **CD**.
- 4** Set CDs in the rack.
(= page 14.)
- 5** Press **DISC/TRACK** to select the CD selection mode.
(The indicator illuminates with a green color.)
- 6** Turn **JOG** to select the desired CD number.
- 7** While the CD number is flashing (approx. 10 seconds) Press **● REC/STOP** to start recording.
 - If you selected ◀▶ in step 2, the direction will automatically change to ▶ when recording starts.
 - The recording will proceed from the first track on the selected CD.
 - The tape deck stops automatically when the CD is finished.

To stop recording

- To add a 4 second silent interval before stopping.
Press **■**. The CD will stop automatically too.
- To stop recording without a silent interval.
Press **● REC/STOP**. The CD will stop automatically too.

To start recording on the reverse side

- Load a tape and change the tape direction as following.
1. Press **TAPE DECK 1/2** and select tape deck 2.
 2. Press **◀** and immediately thereafter **■**. The tape direction will be shown as "◀".

To record from a specific point on a tape

Before recording, advance the tape to the point from where you want to start recording.

To record programmed tracks

1. After step 4, program the track you want (= page 18, steps 2 to 6).
2. Press **● REC/STOP** to start recording.

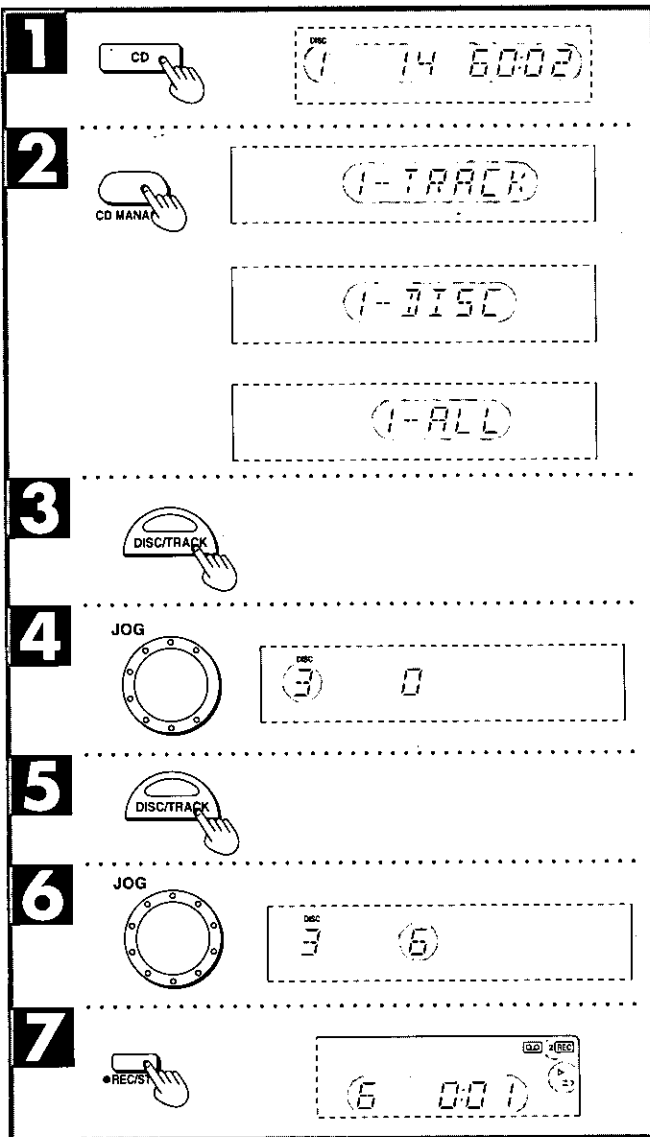
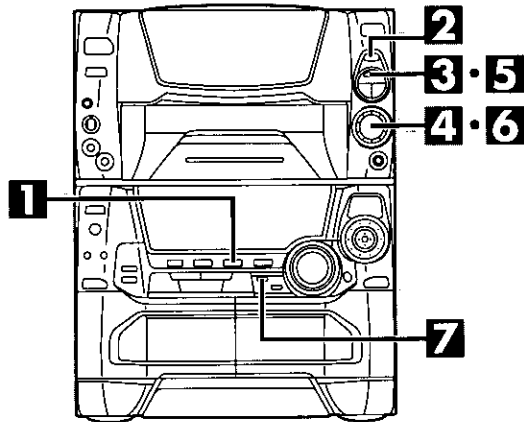
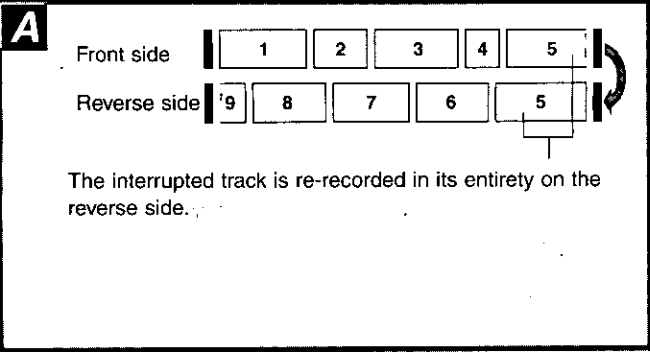

Recording from CDs

To record special CDs and tracks (CD MANAGER function)

This function makes it easier for you to select special CDs and tracks from amongst those loaded in the player.

•While recording, if a track is cut off in the middle at the end of the front side, it is re-recorded from the beginning, on the reverse side.

A

•At the end of the reverse side recording stops and the track playing at that time is interrupted.

Before recording

Prepare the tape you want to use (→ page 34, steps 1 and 2).

1 Press CD.

Ensure CD is stopped.

2 Press CD MANAGER to select the desired mode.

Every time you press the button;

1-TRACK → 1-DISC → 1-ALL

↑ NORMAL ↓

(OFF)

1-TRACK: Only one particular track is recorded.

1-DISC: The tracks on only one particular disc are recorded.

1-ALL: The same track numbers on each of the CDs are recorded in succession.

(NORMAL: The original display is restored in about 3 seconds.)

3 Press DISC/TRACK to select the CD selection mode.

(The indicator illuminates with a green color.)

4 Turn JOG to select the desired CD number.

Note

This step is not required if 1-All was selected in step 2.

5 Press DISC/TRACK to select the track selection mode.

(The indicator illuminates with an orange color.)

6 Turn JOG to select the desired track number.

Note

This step is not required if 1-DISC was selected in step 2.

7 Press ● REC/STOP to start recording.

To stop recording

•To add a 4 second silent interval before stopping

Press ■. The CD will automatically stop too.

•To stop recording without a silent interval

Press ● REC/STOP. The CD will stop automatically too.

Tape-to-tape recording

The recording level will be recorded as they are on the tape being played back.

1 Press TAPE.

2 Press \blacktriangle OPEN on both decks and insert the tapes.

For playback: Into deck 1

For recording: Into deck 2

Close the holders by hand.

Tape direction is automatically set to "▶".

3 Press REV MODE to select the reverse mode.

Every time you press the button;

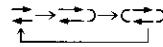

▶: One side is recorded, then recording stops automatically.

↔, ↔ with curved arrow: Both sides (front side → reverse side) are recorded, then recording stops automatically.

4 Press TAPE EDIT to start recording.

• If you selected ↔ with curved arrow in step 3, the direction will automatically change to ▶ when recording starts.

To stop recording:

Press ■.

Both decks will stop.

To start recording on the reverse side

Load a tape and change the tape direction as following.

1. Press TAPE DECK 1/2 and select tape deck 2.

2. Press ◀ and immediately thereafter ■. The tape direction will be shown as "◀".

To record from a specific point on a tape

Before recording, advance the tape to the point from where you want to start recording.

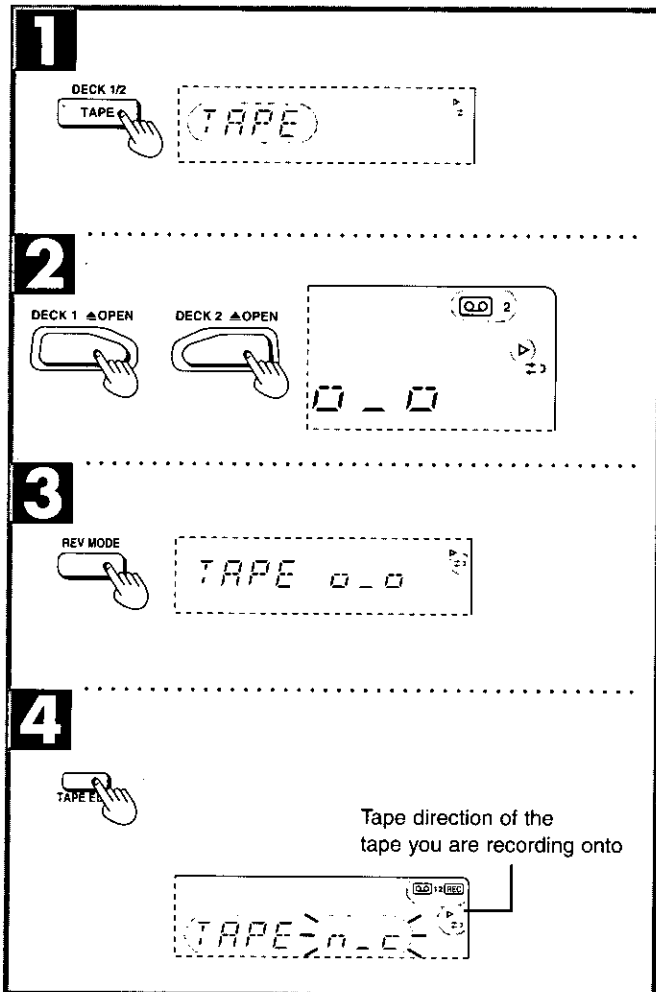
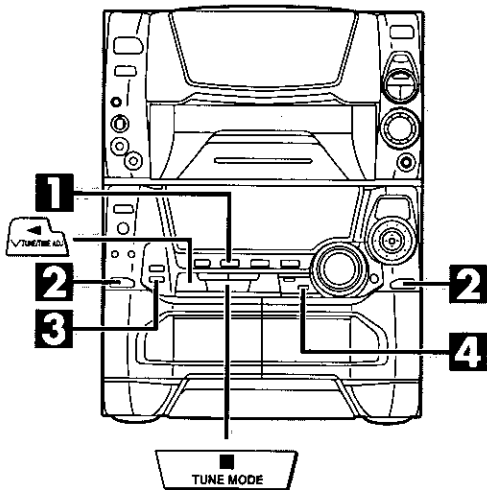

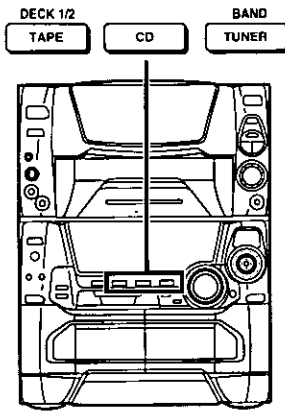
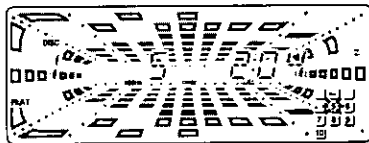
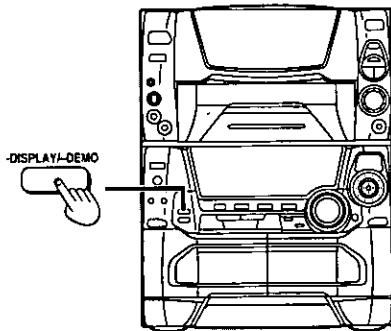
A**B**

(OFF) mode

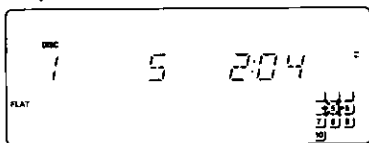

In the off mode no spectrum analyzer will appear.

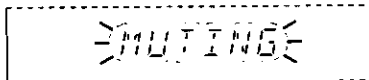
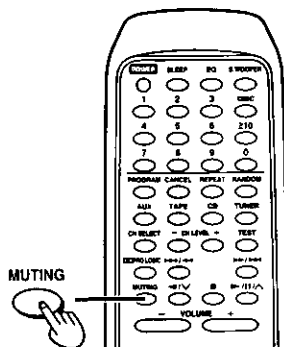
C

Convenient functions

One-touch play

When the system is on standby, playing starts automatically when you press one of the following buttons.

Listening to radio broadcasts

TUNER

The station heard previously is tuned in.

Listening to compact discs

CD

Play starts from track 1 of the CD played previously.

Listening to tapes

TAPE

Playback starts from deck 2 if tapes have been put in both decks.

Switching displays

Press **DISPLAY/DEMO** to select the desired spectrum analyzer.

Every time you press the button;

Aurora → (OFF) → Normal

└─ Peak hold ─┘

To mute the volume

by remote control only

This feature is convenient when you have a telephone call, etc.

Press **MUTING**.

Press the button again to cancel.

"MUTING" goes out.

Muting can also be cancelled by lowering the volume all the way (--dB).

When the system is turned off, muting is automatically cancelled.

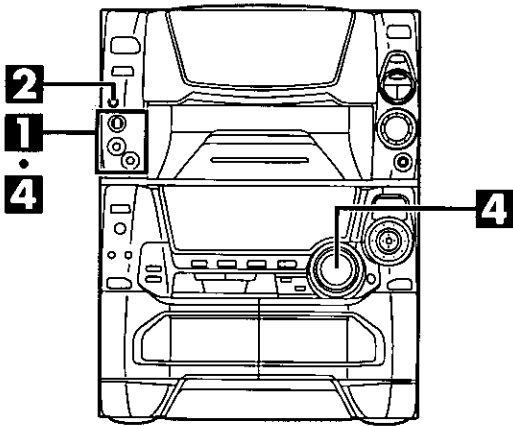

1

2

4

Singing along with KARAOKE

SC-AK95 only

This system lets you enjoy KARAOKE with audio CDs and audio tapes.

1 First, lower volume with MIC VOL, then connect the microphone(s).
Plug type: 3.5 mm (1/8") monaural

2 Press KARAOKE to select the voice mode.
Every time you press the button;
V•MUTE → MONO•L → MONO•R
↑ (OFF) ↓

Voice mode selection

If you want to use the KARAOKE function, check first whether or not your software is formatted for KARAOKE and then select the voice mode as indicated below.

- : Appropriate
- : For practice, etc.

Software Voice modes	KARAOKE		Non-KARAOKE
	Sound multiplex	Stereo	
(OFF)	● (Background music+Voice)	○	● (For singing along)
V•MUTE	—	—	○
MONO•L	○ (Background music)	—	—
MONO•R	● (Voice)	—	—

Note

A bar is indicated in the above table when the voice mode is least effective. It is better to avoid using the mode in such cases.

V.MUTE function

The voice portion of the track is blocked out but not the background music.

You need software recorded in stereo sound if you want to use the voice mute function. Voice and/or static may be reproduced with the following types of software.

- Software recorded in monaural
- Classical music, or works performed by a limited number of instruments
- Chorus works or duets

3 Start the source (CD, etc.).

4 Adjust volume with VOLUME and MIC VOL and sing along.

To cancel the KARAOKE

Press KARAOKE to select "(OFF)" mode.

Note

- If a strange noise (squealing or howling) is emitted during use, move the microphone away from the speakers, or turn down the microphone volume.
- When you are not using the microphone, disconnect it from the MIC jack, and turn down the microphone volume level to MIN.
- Sound quality and sound field can be adjusted when using KARAOKE but recording will be unaffected.

Singing along with KARAOKE

To record your "KARAOKE" performance

- 1** First, lower volume with MIC VOL then, connect the microphone(s).
- 2** Press DECK 2 \blacktriangle OPEN to insert the tape and then select the reverse mode.
- 3** Press KARAOKE to select the voice mode.
- 4** Start recording and KARAOKE performance.
 - When singing with CDs
Press \bullet REC/STOP and start KARAOKE performance.
 - When singing with tapes
Press TAPE EDIT and start KARAOKE performance.

Note

- To playback the recorded tape, be sure to press KARAOKE to select the "(OFF)" mode.
- You cannot play or record KARAOKE with radio backing.

To record your voice

1. First, lower volume with MIC VOL then, connect the microphone(s).
2. Press DECK 2 \blacktriangle OPEN to insert a tape and then select the reverse mode.
3. Press TAPE.
4. Press \bullet REC/STOP to start recording.
5. Speak through the microphone and adjust volume with VOLUME and MIC VOL.

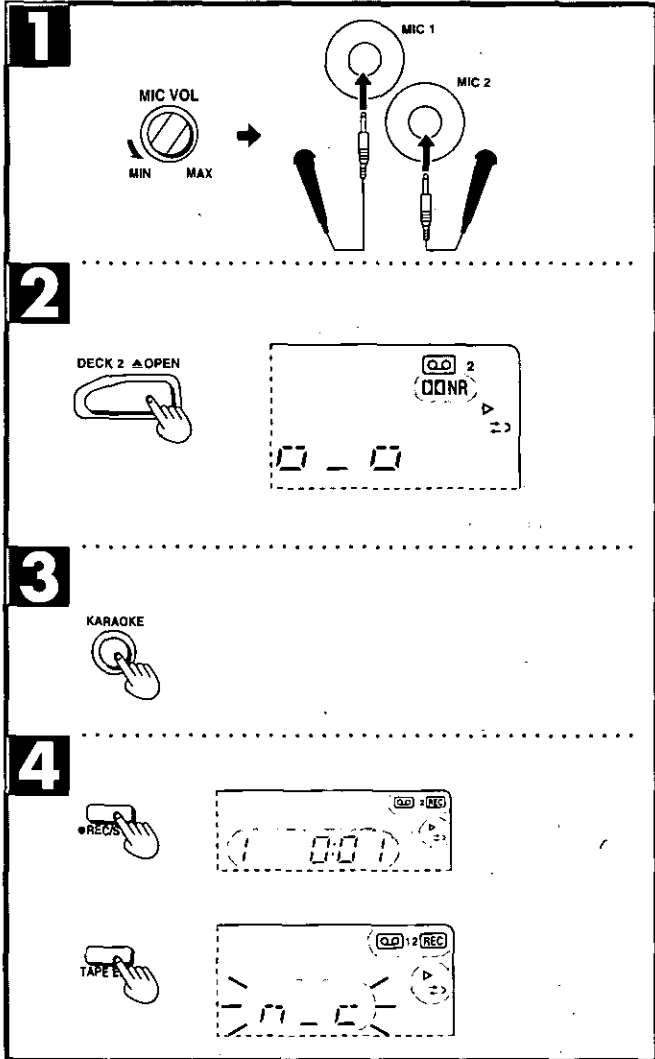
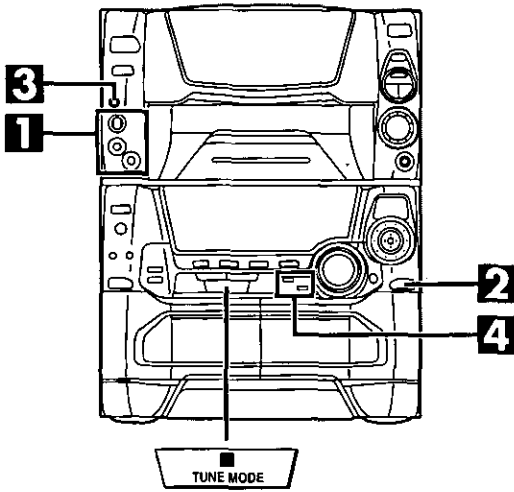

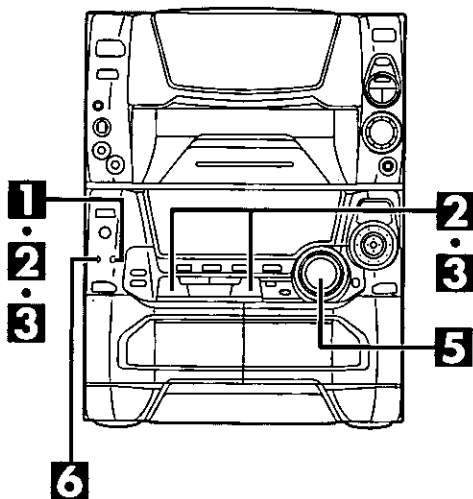

1

2

①

②

3

①

②

5

6

Using the timer

Using the play timer

Select this timer when you want to use the timer as an alarm clock. You can wake up listening to music (CD, tuner, tape or aux) at a desired volume level and time.

Preparations

- Make sure that you have completed "Setting the time" (→ page 11).
- Switch on the power.

The figure shows how to set the play timer from 6:30 a.m. to 7:40 a.m.

1 Press CLOCK/TIMER to select "⊙ PLAY".

Every time you press the button;
 CLOCK → ⊙ PLAY → ⊙ REC
 ↑ Previous display ↓

2 "ON" time setting

(Within 8 seconds or so)

- ① Press \vee or \wedge to select the starting time.
- ② Press CLOCK/TIMER.

3 "OFF" time setting

- ① Press \vee or \wedge to select the ending time.
- ② Press CLOCK/TIMER.

4 Source selection

Select the desired source and then prepare for playing.

To play CD(s)

Press CD and insert CD(s).

If more than 1 CD is loaded

- ① Press DISC/TRACK to select the CD selection mode. (The indicator illuminates with a green color.)
- ② Turn JOG to select the desired CD number.
- ③ Press CD \blacktriangleright and then press \blacksquare .

Note

Disc selection does not become part of the timer memory.

To play tape(s)

Press TAPE and insert tape(s).

If tapes are loaded in both decks, playback will start from deck 2.

To play the radio

Press TUNER and tune in the desired station.

To play a unit connected to the "AUX" terminals

Press AUX.

5 Play volume setting

Set the playback volume.

6 Press ⊙ PLAY/⊙ REC to select "⊙ PLAY".

Every time you press the button;
 ⊙ PLAY → ⊙ REC
 ↑ Out (OFF) ↓

Power will shut OFF automatically in a few seconds.

The timer play will start at the preset time with volume increasing gradually up to the volume level you preset.

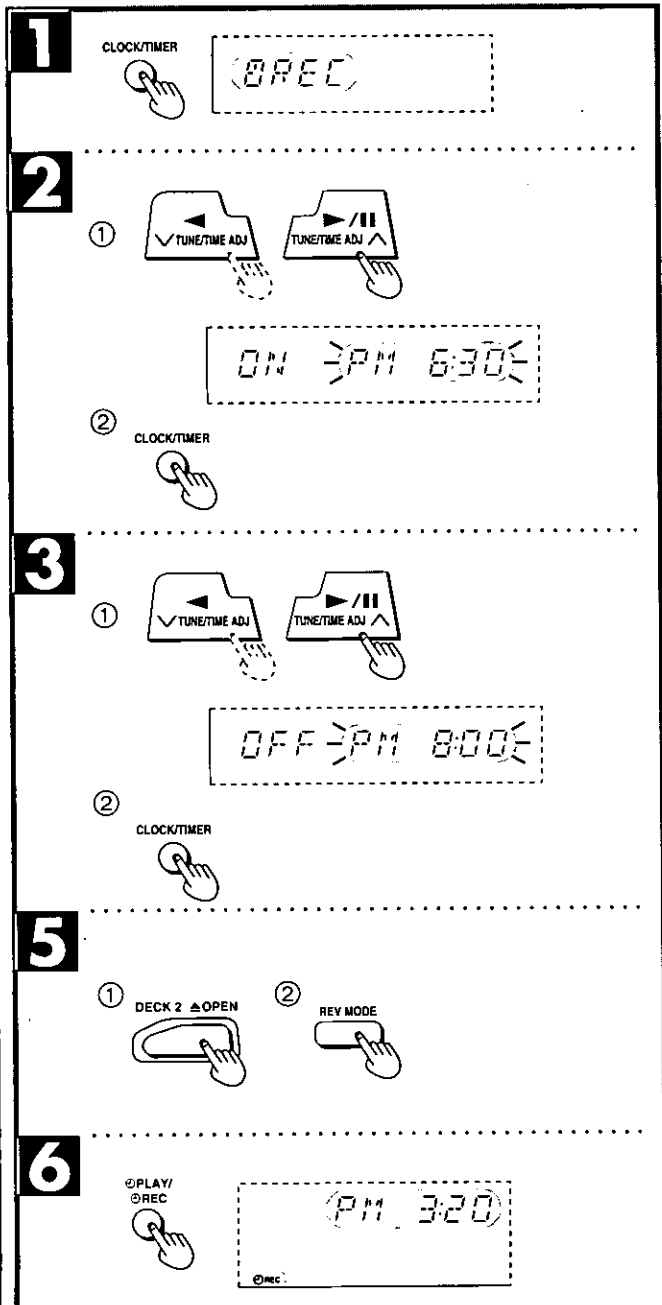
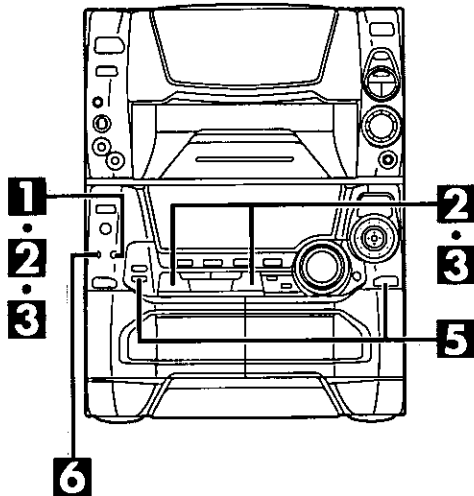

Using the timer

Using the record timer

Select this timer when you want to use the timer to record a mid-night program or while you are out.

Preparations

- Make sure that you have completed "Setting the time" (→ page 11).
- Switch on the power.

Set the timer at least 2 minutes before you want to start recording.

The figure shows how to set the record timer from 6:30 p.m. to 8:00 p.m.

1 Press CLOCK/TIMER to select "⊙ REC".

Every time you press the button;

CLOCK → ⊙ PLAY → ⊙ REC
 ← Previous display ←

2 "ON" time setting

(Within 8 seconds or so)

- 1 Press ∇ or \blacktriangle to select the starting time.
- 2 Press CLOCK/TIMER.

3 "OFF" time setting

- 1 Press ∇ or \blacktriangle to select the ending time.
- 2 Press CLOCK/TIMER.

4 Source selection

Select the desired source and then prepare for recording.

To record from the radio

Press TUNER to select the band and tune in the desired station.

To record from a unit connected to the "AUX" terminals
 Press AUX.

5 Prepare for recording.

1. Insert a tape into deck 2 with the side on which the recording will start facing you.
2. Select the reverse mode.

Note

Reverse mode does not become part of the timer memory.

6 Press ⊙ PLAY/⊙ REC to select "⊙ REC".

Every time you press the button;

⊙ PLAY → ⊙ REC
 ← (OFF) ←

Power will shut OFF automatically in a few seconds.

About 30 seconds before the set time, the stereo mutes all sound automatically.

Using the play/record timer

To switch the timer OFF

Press \odot PLAY/ \odot REC and check " \odot PLAY" (for play timer) or " \odot REC" (for record timer) goes out.

If you set the timer incorrectly

Repeat the procedure from step 1.

To check settings

Press CLOCK/TIMER to select " \odot PLAY" (for play timer) or " \odot REC" (for record timer).

Two seconds later, the display will change in the following order.

• For play timer

- ① Play start time
- ② Play end time
- ③ Play source
- ④ Playback volume

• For record timer

- ① Recording start time
- ② Recording end time
- ③ Recording source

You can check the settings even when the system is OFF.

To enjoy a source after the timer setting is completed

The volume level and music source are stored in the timer memory and the disc will start in these preset conditions. However the disc number, and reverse mode do not get stored in the timer memory.

1. After step 6, turn on the power and start playing the desired source.
2. Reset the disc number, and reverse mode if you have changed either of them, confirm that a disc or cassette is inserted, then press POWER to put the unit on standby.

Turning the timers ON/OFF

As long as " \odot PLAY" or " \odot REC" is displayed, the timer will come ON everyday as set.

You can turn the timer ON/OFF by pressing \odot PLAY/ \odot REC while the system is OFF.

Remember that when " \odot PLAY" or " \odot REC" is displayed, the timer is ON. When not displayed, the timer is OFF.

Note

- If the power is on, the timer will not function. The system must be in the standby mode.
- If you switch the power to the standby mode while the play/record timer is functioning, the OFF time setting will not be activated.
- If AUX is selected as the source, when the timer comes ON, the system will turn ON and will engage "AUX" as the source. If you want to playback or record from a connected component, set the component's timer to the same time. (See the instruction manual that came with the component.)
- The play timer cannot be used in combination with the record timer.

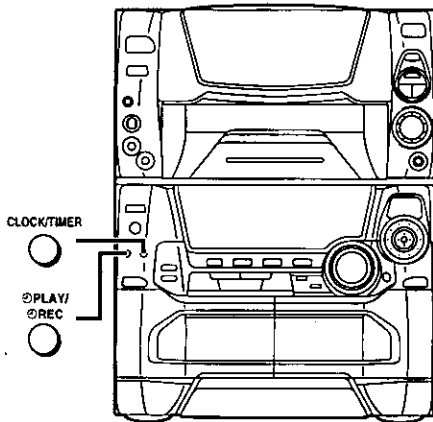

A**B**

How to hold CDs

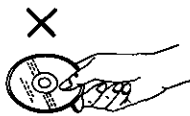
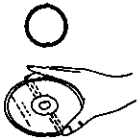

Do not touch the recorded surface

C

How to clean CDs

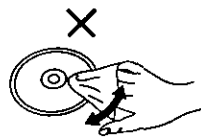
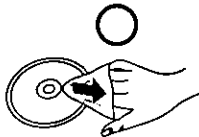

Wipe from inside outward.

D

How to take up tape slack

**E**

Side A

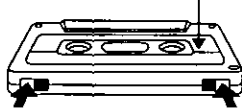

Tab for side "B"

Tab for side "A"

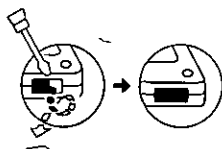

To re-record on a protected cassette
Cover the hole with adhesive tape

Normal position tape

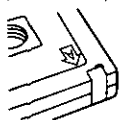

Hi-position tape

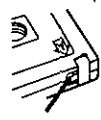

Detection hole

Concerning CDs

With this player, you can only play compact discs having this mark.

However, do not use irregular shape CDs. CDs of this sort can damage the unit. **A**



Handling precautions

Handle CDs as shown on the left (**B**–**C**).

- If you are taking the disc from a cold to a warm environment, moisture may form on the disc. Wipe this off with a soft, dry, lintfree cloth before using the disc.
- Do not write on the label side with a ball-point or other writing instrument.
- Do not use record cleaning sprays, benzene, thinner, static electricity prevention liquids or any other solvent.
- Do not attach labels or stickers to CDs. (Do not use CDs with exposed adhesive from tape or left over peeled off stickers.)
- Do not use scratch-proof protectors or covers other than those specified for use with this system.

Storage precautions

Be sure to store discs in their cases to protect them from dust, scratches, and warping.

Do not place or store discs in the following places

- Locations exposed to direct sunlight
- Humid or dusty locations
- Locations directly exposed to a heat vent or heating appliance
- In the glove compartment or on the rear deck of an automobile

Concerning cassette tapes

Selection of cassette tapes

Tapes can get caught on the capstans. Use caution with the following types of tapes.

Cassette tapes exceeding 100 minutes

These tapes are made of a thin film material. Do not repeatedly advance and stop the tape, fast-forward it or rewind it.

Endless-tapes

For this unit, it is recommended to use tapes which are appropriate to the auto reverse mechanism.

Always read the instructions provided with your tapes.

Tape slack **D**

Tape slack may cause the tape to break.

Use a pencil or similar object to take up the slack.

Erasure prevention **E**

Use a screwdriver or similar object to break out the tab.

To re-record on a protected cassette

Cover the hole with adhesive tape

Do not cover the detection hole on hi-position tapes

Storage precautions

Do not place or store tapes in the following places;

- In high temperature (35°C or higher) or high humidity (80% or higher) areas
- In a strong magnetic field (near a speaker, on top of a TV, etc.) This can erase a recording.
- Locations exposed to direct sunlight.

AMPLIFIER SECTION

SC-AK95

Rated minimum sine wave
RMS power output
 1.0% total harmonic distortion
 1 kHz both channels driven
 85 W per channel (6Ω)
 60 Hz–13 kHz both channels driven
 80 W per channel (6Ω)

Power output in the Dolby Pro Logic
 mode 1.0% total harmonic distortion at
 1 kHz
Front 85 W per channel (6Ω)
Center 35 W (8Ω)
Surround 17.5 W per channel (4Ω)
Total power output 240 W

Input sensitivity
AUX 250 mV
MIC 0.7 mV

Input impedance
AUX 10 kΩ
MIC 600Ω

AMPLIFIER SECTION

SC-AK75

Rated minimum sine wave
RMS power output
 1.0% total harmonic distortion
 1 kHz both channels driven
 70 W per channel (6Ω)
 60 Hz–12 kHz both channels driven
 60 W per channel (6Ω)

Input sensitivity
AUX 250 mV

Input impedance
AUX 10 kΩ

FM TUNER SECTION

Frequency range
 87.9–107.9 MHz (200 kHz steps)
 87.5–108.0 MHz (100 kHz steps)

Sensitivity 16.3 dBf (1.8 μV, IHF 58)

Antenna terminal(s) 75Ω (unbalanced)

AM TUNER SECTION

Frequency range 520–1710 kHz

Sensitivity
 S/N 20 dB 500 μV/m

CASSETTE DECK SECTION

Track system 4 track, 2 channel

Heads
Record/playback Solid permalloy head
Erasure Double gap ferrite head

Motor DC servo motor

Recording system AC bias 100 kHz

Erasing system AC erase

Tape speed 4.8 cm/s (1⁷/₈ ips)

Frequency response
 (+3, –6 dB) at DECK OUT
NORMAL 35 Hz–14 kHz
HIGH POSITION 35 Hz–14 kHz

S/N 50 dB (A weighted)

Wow and flutter 0.18% (WRMS)

Fast forward and rewind times
 Approx. 120 seconds
 with C-60 cassette tape

CD SECTION

Sampling frequency 44.1 kHz

Decoding 16 bit linear

Beam source/wave length
 Semiconductor laser/780 nm

Number of channels Stereo

Frequency response 20 Hz–20 kHz (+1, –2 dB)

S/N

CD UNIT OUT 95 dB (JIS.A)

Wow and flutter Below measurable limit

Digital filter 8 fs

D/A converter MASH (1 bit DAC)

SPEAKER SECTION

FRONT SPEAKER

Type 4 way speaker system

Speaker(s)
Super woofer 17 cm cone type
Woofer 12 cm cone type
Midrange 6 cm cone type
Tweeter Piezo type

Impedance Total 6Ω

Input power Total 170 W (Music)
 Total 85 W (DIN)

Output sound pressure level 84 dB/W (1.0 m)

Cross over frequency 200 Hz, 3.5 kHz

Frequency range 45 Hz–22 kHz (–16 dB)
 55 Hz–20 kHz (–10 dB)

Dimensions (W×H×D)
 250×345×310 mm
 (9²⁷/₃₂"×13¹⁹/₃₂"×12⁷/₃₂"

Weight 4.9 kg (10.8 lb.)

CENTER SPEAKER

SC-AK95 only

Type 1 way, 1 speaker

Speaker
Full range: 8 cm cone type

Impedance 8Ω

Input power 70 W (Music), 35 W (DIN)

Output sound pressure level 85 dB/W (1.0 m)

Frequency range 110 Hz–18 kHz (–16 dB)

Dimensions (W×H×D)
 252×121×150 mm (9²⁹/₃₂"×4³/₄"×5²⁹/₃₂"

Weight 0.9 kg (2.0 lb.)

SURROUND SPEAKER

SC-AK95

Type 1 way, 1 speaker, Dipole type

Speaker
Full range: 8 cm cone type

Impedance 4Ω

Input power 35 W (Music), 17.5 W (DIN)

Output sound pressure level 85 dB/W (1.0 m)

Frequency range 190 Hz–20 kHz (–16 dB)

Dimensions (W×H×D)
 180×108×142 mm (7³/₃₂"×4¹/₄"×5¹⁹/₃₂"

Weight 0.7 kg (1.5 lb.)

SURROUND SPEAKER

SC-AK75

Type 1 way, 1 speaker, Dipole type

Speaker
Full range: 8 cm cone type

Impedance 32Ω

Input power 30 W (Music), 15 W (DIN)

Output sound pressure level 85 dB/W (1.0 m)

Frequency range 190 Hz–20 kHz (–16 dB)

Dimensions (W×H×D)
 180×108×142 mm (7³/₃₂"×4¹/₄"×5¹⁹/₃₂"

Weight 0.7 kg (1.5 lb.)

GENERAL SC-AK95

Power supply AC 120 V, 60 Hz

Power consumptions 165 W

Dimensions (W×H×D)
 270×350×398 mm
 (10⁵/₈"×13²⁵/₃₂"×15²¹/₃₂"

Weight 10.3 kg (22.9 lb.)

GENERAL SC-AK75

Power supply AC 120 V, 60 Hz

Power consumptions 130 W

Dimensions (W×H×D)
 270×350×398 mm
 (10⁵/₈"×13²⁵/₃₂"×15²¹/₃₂"

Weight 9.5 kg (21.1 lb.)

Notes:

- Specifications are subject to change without notice. Weight and dimensions are approximate.
- Total harmonic distortion is measured by the digital spectrum analyzer.

MASH is a trademark of NTT.

Troubleshooting guide

Before requesting service for this unit, check the chart below for a possible cause of the problem you are experiencing. Some simple checks or a minor adjustment on your part may eliminate the problem and restore proper operation.

If you are in doubt about some of the check points, or if the remedies indicated in the chart do not solve the problem, refer to the directory of Authorized Service Centers (enclosed with this unit) to locate a convenient service center, or consult your dealer for instructions.

For detailed instructions, contact an authorized servicenter in the U.S.A. and Panasonic Canada Inc. Customer Care Center in Canada.

In the U.S.A. 1-800-211-7262 or web site (<http://www.panasonic.com>)

In Canada 905-624-5505 or web site (www.panasonic.ca/faq.html)

Reference

Problem	Probable cause(s)	Suggested remedy	Reference page(s)
Common problems			
There is no sound when the power is ON.	Volume is set too low.	Adjust the volume level with the volume control.	13, 15, 25
The location of the various musical instruments is not well defined.	The (+) and (-) connections to one of the speakers are reversed.	Connect the speaker cords correctly.	7
The left and right sounds are reversed.	The left and right connections to the speaker are reversed.	Connect the speaker cords correctly.	7
LOW frequency sounds cannot be heard.	Either the left or the right LOW speaker cable is not connected.	Connect the left and right speaker cables to the LOW terminals.	7
When listening to an external unit, the left and right sounds are reversed.	The left and right connections to the external unit are reversed.	Connect the external unit's cord correctly.	8
There is no sound when a source is being played.	The (+) and (-) wires of the speaker cords are shorted.	Switch the system to the standby mode, and reconnect the speaker cords so that they are not shorted. Then switch on the power.	7
"ERROR" message appears on the display.	Wrong operation has been done.	Operate the unit correctly by following the operating instructions.	
"---:---" appears on the display.	<ul style="list-style-type: none"> ● You plugged the power cord in for the first time. ● There was a power failure recently. 	Set the time.	11

While listening to FM broadcasts			
There is a "rushing noise" during a stereo broadcast which is not audible during a monaural broadcast.	The transmitting station is a long distance away.	If you are using an indoor antenna, change to an outdoor antenna.	8
You hear excessive noise during a stereo broadcast, and occasionally the sound disappears.	The installation location and orientation of the antenna are unsuitable.		
The stereo indicator ("STEREO") flickers and does not light completely.	The transmitting station is a long distance away. The power of the TV set or VCR is ON.		
The sound during a stereo broadcast is highly distorted.	There is a building or mountain nearby. [Distortion is caused by interference between the signal from the transmitting station (direct wave) and the signal reflected from the building or mountain (reflected wave).]	Use a high-grade outdoor antenna, and install it in a good location, height, and orientation for reception.	8

While listening to AM broadcasts			
You hear an unusual beat sound.	You are using the system at the same time you are playing a TV set.	Switch off the TV set, or use the system further away from it.	
You hear a low-frequency hum.	The antenna wire is near the power cord.	Separate the antenna wire from the power cord.	

Problem	Probable cause(s)	Suggested remedy	Reference page(s)
---------	-------------------	------------------	-------------------

When there is a television set nearby

The picture on the TV disappears or stripes appear on the screen.	The location and orientation of the unit's FM antenna are incorrect.	If you are using an indoor antenna, change to an outdoor antenna.	8
	The wiring at the back of the system is unsuitable.	Separate the antenna wire of the TV set from the system.	

When listening to tapes

Sound is low, intermittent, poor quality, noisy, scratchy, or unsteady.	Heads are dirty.	Clean the heads.	47
The deck does not enter the recording mode.	The erase-prevention tabs have been removed from the cassette.	Attach tape to cover the space left by removal of the erase-prevention tabs.	44

While listening to CDs

The display does not show the correct indication. CD play does not start when you press the play button.	The CD label is facing left.	Set the CD with the label facing to the right.	14
	The CD is dirty.	Wipe the CD with a soft cloth.	44
	The CD is scratched.	Replace the CD with a new one.	
	The CD is badly warped.		
	The CD is nonstandard.	Replace the CD with a different one.	44
	There is condensation inside the CD changer.	Wait for 60 minutes before using the CD changer.	
A certain music passage can't be played correctly.	The CD is dirty.	Wipe the CD with a soft cloth.	44
The error message "DISC TAKE OUT" appears on the display and the changer stops operating.	A disc has been put in the slot of the CD in play.	Remove the CD whose number is displayed and close the rack panel.	
The CD does not return to its slot. ("DISC TAKE OUT" appears on the display.)	Because of light or noise, the changer has detected a CD in the slot of the CD being played, even though it is empty.	Check whether another CD is in the slot or not. If not, hold down the ■ (stop) button for 4 seconds. The changer will then eject the CD. If this proves to be ineffective, contact the place of purchase.	

While using the remote control

The system cannot be operated with the remote control.	The batteries are installed in the reverse polarity.	Re-insert the batteries in the correct polarity.	5
	The batteries are run-down.	Replace the batteries with new batteries.	5

Maintenance

If the surfaces are dirty

To clean this unit, wipe with a soft, dry cloth. If the surfaces are extremely dirty, use a soft cloth dipped in a soap-and-water solution or a weak detergent solution.

- Never use alcohol, paint thinner, or benzine to clean this unit.
- Before using a chemically impregnated cloth, read the instructions that came with the cloth carefully.

For a cleaner crisper sound

We recommend that you periodically clean parts (the shaded portion in the figure below) the tape contacts like the heads. Do not use any liquid other than alcohol for head cleaning.

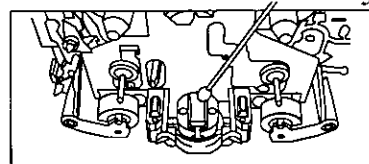

Before moving or shipping this system

Before moving your system to another location, be sure to remove all discs from the rack and turn off the system. The changer mechanism automatically locks when the system is turned off, to protect it against damage in transport. Therefore, always press POWER and make sure "GOOD BYE" appears on the display before you unplug the system. Failure to do so will expose the CDs and the system to the risk of severe damage.

Product service

Do not attempt to remove the cover(s) or repair the unit yourself. Refer servicing to qualified personnel only.

Product information

For product service, product information or assistance with product operation, refer to the servicenter directory.

Panasonic Consumer Electronics Company, Division of Matsushita Electric Corporation of America
One Panasonic Way Secaucus,
New Jersey 07094
<http://www.panasonic.com>

Panasonic Sales Company, Division of Matsushita Electric of Puerto Rico, Inc. ("PSC")
Ave. 65 de Infantería, Km. 9.5
San Gabriel Industrial Park, Carolina,
Puerto Rico 00985

Panasonic Canada Inc. (En)
5770 Ambler Drive,
Mississauga, Ontario
L4W 2T3
www.panasonic.ca

RQT4220-1P
F1297C1028 (D)